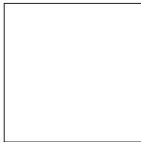
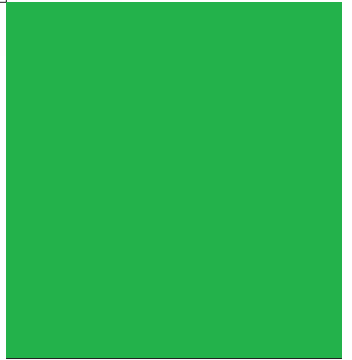
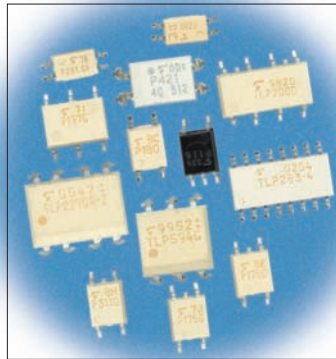
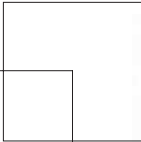



Photo Couplers and Photo Relays

2006



Preface

Safety, performance and power consumption criteria are driving the development of highly efficient photocoupler devices.

Electrical isolation is a familiar requirement in the design of many systems. Motor controllers, power supply electronics, data communications and general-purpose switching-type applications all require components that form a reliable, controllable electrical barrier between two parts of a circuit isolation serves a number of purposes. For instance, the intrinsic function of devices such as relays and switches is to toggle between on- and off-states as a part of a control system. Transistor couplers and triac couplers, in contrast, can more often be regarded as signal conversion devices that allow logic-level electronics to control higher currents and voltages. At the same time, these devices may also protect the sensitive electronic portion of the system from the potential damage that can be caused by accidental contact with power circuitry. Just as important is their role in protecting the human user of the equipment from injury, and in preventing the transmission of noise from one part of a circuit to another – in effect to protect the two parts of the circuit from “injuring” the signals of the other. Toshiba’s photocouplers incorporate into a white mold package, a combination of either GaAs infrared LEDs or GaAlAs infrared LEDs and silicon photo-detectors. GaAlAs LEDs are adopted in the high speed Photo-IC types by utilizing their high speed and high light power.

Toshiba offers a wide line up of leadfree products. Pb-free couplers are indicated with “(F)” in the list on page S.6ff and utilize either Ni-Pd-Au or Sn-AG as plating material. All Pb-free couplers are RoHS compliant.

Extensive line of products

0. General purpose coupler: AC or DC input, Transistor output
1. Photo-IC couplers: High speed and advanced functions (Power drivers)
2. Photo-Triac: Phototriac output with zerocross or nonzerocross
3. AC power couplers: high output current (used with a power triac)
4. Photovoltaic couplers: MOSFET gate drive
5. Photorelays (MOSFET output devices): AC/DC switches. Mechanical relay replacement.

Safety Standard Approvals

UL recognition in File No. E67349 has been obtained on most of TOSHIBA’s photocouplers. EN60747-5-2 approved photocouplers are also supplied along with a wide selection of output (transistor, thyristor, triac, IC output and photorelay). The designs of these devices meet other standards including IEC380/VDE0806, IEC60950/EN60950 and IEC60065/EN60065.

Small-Package Products

TOSHIBA offers a wide variety of small packaged photocouplers to meet requirements for size reduction and space savings in smaller electronic equipment. The devices include Mini-flat packaged (MFSOP) products and half-pitch (1.27 mm) mini-flat SOP packaged products.

Overseas Manufactured Photocouplers

TOSHIBA semiconductor Thailand manufactures general-purpose 4-pin phototransistor output devices to help customers to easily procure components for overseas assembly of end products.

Contents

1. New Products	p. 3
2. Photocoupler Product List	p. 5
3. Recommended Products	p. 8
4. Selection Guide	p. 10
5. Package Information	p. 35
6. Supplementary Information	p. 50
7. Safety Standard Approved Photocouplers	p. 57
8. Photocoupler Application Circuit Example	p. 61
9. Competitor Cross Reference	p. 77

IGBT/MOSFET Drive Coupler IC

TLP350

● Features



- ✓ IGBT Direct Drive
- ✓ Direct replacement of current TLP250
- ✓ Low power consumption with Bi-CMOS technology
- ✓ UVLO Function

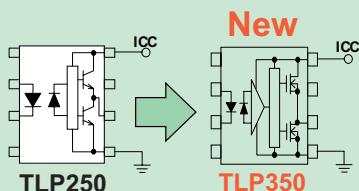

● Application

- IGBT Driver
- Power MOSFET Driver
- Inverter

Supply Current (I_{cc})

80% reduced !!

TLP250 TLP350
 I_{cc} < 11mA >> I_{cc} < 2mA
 (330mW) >> (60mW)

Wide Top Range

TLP250 TLP350
 -20 to 85 deg >> -40 to 100 deg

Delay time guarantee

t_{pLH}/t_{pHL} < 0.5us @ -40 ~ 100 deg

Photo-IC Output Couplers

with New Package SDIP

The devices housed in a Shrink Dual Inline Package (SDIP) meet the requirements for reinforced insulation. Small photo-IC output couplers, meeting the international safety standards, were housed in a widely used 8-pin DIP package; however, housing these devices in newly developed SDIP package can reduce mounting area to 50% than that of the conventional package. TOSHIBA has newly lined up several types of devices with this package, high-speed photo-IC couplers for data transfer, IGBT/MOSFET, IPM and general-purpose photo-IC.

- 6-pin SDIP (50% smaller than 8-pin DIP package)
- SMD
- International safety standards: UL-approved, TUV(EN60747-5-2) design which meets safety standard
- Isolation voltage: BVs = 5000 Vrms (min)
- Structure parameters

	7.62-mm pitch TLPxxx	10.16-mm pitch TLPxxxF
Creepage distance	7.0 mm (min)	8.0 mm (min)
Clearance	7.0 mm (min)	8.0 mm (min)
Isolation thickness	0.4 mm (min)	0.4 mm (min)

● Package Dimensions and Characteristics

Part Number	Data Rate or t _{pHL} /t _{pLH} (typ.)	Output	Device Type
TLP701	0.25 μs	±0.6 A peak current	IGBT/MOSFET direct drive
TLP716	45 ns	Totem pole output	High-speed data transfer
TLP719	1 Mbit/s	CTR 20% (min)	General-purpose

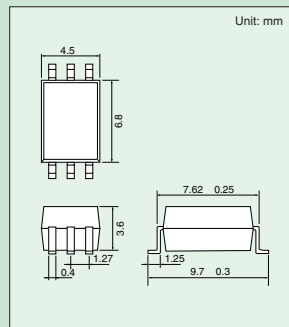

DIP4pin Triac-coupler

TLP360J/361J/363J

DIP6 TLP3052(S)
TLP665J(S)

DIP4 TLP360J

7.12mm

4.58mm

space saving

TLP360J: Non-zero cross type
TLP361J/363J: Zero cross type

1.Small Package: DIP4
2.High Isolation: BVs=5kV
3.World wide Safety standard
comply with or Pending approval of UL,VDE(TUV),BSI,SEMKO

DIP8 1.2A Output AC Power TriacCoupler

TLP3616/3617

DIP16 TLP3526/3527

DIP8 TLP3616/3617

19.82mm

9.66mm

ZC type:TLP3527

ZC type:TLP3617

Features

- 1.Small Package: DIP8
- 2.Peak off-state voltage : 600V(min)
- 3.On-state current : 1.2Arms(max)
- 4.Inhibit voltage : 20V(max.TLP3617)

Application Example
HA : A/C,RF,W,M,Fan Heater

"F" Lead-Forming is also available

2 Photo Coupler Product List

previous Version	Pb-free Version	Page
6N135	6N135(F)	21
6N136	6N136(F)	21
6N137	6N137(F)	21
6N138	6N138(F)	21
6N139	6N139(F)	21
New	TLP102(F)	21
New	TLP106(F)	21
TLP112	TLP112(F)	21
TLP112A	TLP112A(F)	21
TLP113	TLP113(F)	21
TLP114A	TLP114A(F)	21
TLP115	TLP115(F)	21
TLP115A	TLP115A(F)	21
New	TLP116(F)	21
TLP120	TLP120(F), TLP180(F)	
TLP120-4	TLP180(F) x4	
TLP121	TLP121(F), TLP181(F)	
TLP121-4	TLP181(F) x4	
TLP124	TLP124(F)	10
TLP124-4	TLP124(F) x4	
TLP126	TLP126(F)	10
TLP127	TLP127(F)	16
TLP127-4	TLP127(F) x4	
TLP130	TLP130(F)	10
TLP131	TLP131(F)	10
TLP137	TLP137(F)	10
TLP141G	TLP141G(F)	17
TLP160G	TLP160G(F)	18
TLP160J	TLP160J(F)	18
TLP161G	TLP161G(U,C,F)	18
TLP161J	TLP161J(U,C,F)	18
TLP165G	TLP165G(F)	
TLP165J	TLP165J(F)	18
TLP166G	TLP166G(C,F)	
TLP166J	TLP166J(C,F)	18
TLP168J	TLP168J(U,C,F)	18
TLP172A	TLP172A(F)	26
TLP172G	TLP172G(F)	26
TLP174G	TLP174G(F)	26
TLP174GA	TLP174GA(F)	26
TLP176A	TLP176A(F)	26
TLP176D	TLP176D(F)	26
TLP176G	TLP176G(F)	26
TLP176GA	TLP176GA(F)	26
TLP176GA(ADV)	TLP176GA(ADV,F)	
TLP179D	TLP179D(F)	26
TLP180	TLP180(F)	10
TLP181	TLP181(F)	10
TLP190B	TLP190B(U,C,F)	25
TLP191B	TLP191B(U,C,F)	25
TLP192A	TLP192A(F)	26
TLP192G	TLP192G(F)	26
TLP197A	TLP197A(F)	26
TLP197D	TLP197D(F)	26

previous Version	Pb-free Version	Page
TLP197G	TLP197G(F)	27
TLP197GA	TLP197GA(F)	27
TLP200D	TLP200D(F)	27
TLP202A	TLP202A(F)	27
TLP202G	TLP202G(F)	27
TLP206A	TLP206A(F)	27
TLP206G	TLP206G(F)	27
TLP206GA	TLP206GA(F)	27
TLP209D		27
TLP2200	TLP2200(F)	24
TLP222A	TLP222A(F)	27
TLP222A-2	TLP222A-2(F)	27
TLP222G	TLP222G(F)	28
TLP222G-2	TLP222G-2(F)	28
TLP224G	TLP224G(F)	28
TLP224G-2	TLP224G-2(F)	28
TLP224GA	TLP224GA(F)	
TLP224GA-2	TLP224GA-2(F)	
TLP225A	TLP225A(F)	28
TLP227A	TLP227A(F)	28
TLP227A-2	TLP227A-2(F)	28
TLP227G	TLP227G(F)	28
TLP227G-2	TLP227G-2(F)	28
TLP227GA	TLP227GA(F)	28
TLP227GA-2	TLP227GA-2(F)	28
TLP250	TLP250(F)	22
TLP250INV		22
TLP251	TLP251(F)	22
TLP2530	TLP2530(F)	24
TLP2531	TLP2531(F)	24
TLP2601	TLP2601(F)	24
TLP260J	TLP260J(F)	18
TLP261J	TLP261J(F)?	
TLP2630	TLP2630(F)	24
TLP2631	TLP2631(F)	24
TLP280	TLP280(F)	10
TLP280-4	TLP280-4(F)	10
TLP281	TLP281(F)	11
TLP281-4	TLP281-4(F)	11
TLP283	TLP283(F)	11
TLP283-4	TLP283-4(F)	11
TLP3022(S)	TLP3022(S,F)	19
TLP3023(S)	TLP3023(S,F)	
TLP3031(S)	TLP3031(S,C,F)	
TLP3032(S)	TLP3032(S,C,F)	
TLP3033(S)	TLP3033(S,C,F)	
TLP3041(S)	TLP3041(S,C,F)	
TLP3042(S)	TLP3042(S,C,F)	19
TLP3043(S)	TLP3043(S,C,F)	19
TLP3052(S)	TLP3052(S,F)	19
TLP3061(S)	TLP3061(S,C,F)	
TLP3062(S)	TLP3062(S,C,F)	19
TLP3063(S)	TLP3063(S,C,F)	19
TLP3064(S)	TLP3064(S,C,F)	19

2 Photo Coupler Product List

previous Version	Pb-free Version	Page
TLP3110		29
TLP3111		30
TLP3113	TLP3113(F)	30
TLP3114	TLP3114(F)	30
TLP3115	TLP3115(F)	30
TLP3116	TLP3116(F)	30
TLP3118	TLP3118(F)	
TLP3119	TLP3119(F)	
TLP3120	TLP3120(F)	30
TLP3121	TLP3121(F)	30
TLP3122	TLP3122(F)	30
TLP3125	TLP3125(F)	30
TLP3130	TLP3130(F)	30
TLP3131	TLP3131(F)	30
TLP320	TLP320(F)	11
TLP320-2	TLP320-2(F)	11
TLP320-3	TLP320(F) x3	
TLP320-4	TLP320-4(F)	11
TLP321	TLP321(F)	
TLP321-2	TLP321-2(F)	
TLP321-3	TLP321(F) x3	
TLP321-4	TLP321-4(F)	
TLP3212		31
TLP3213		31
TLP3214		31
TLP3215		31
TLP3216		31
TLP3217		31
TLP3230		31
TLP3231		31
TLP330	TLP330(F)	11
TLP331	TLP331(F)	12
TLP332	TLP332(F)	12
TLP350	TLP350(F)	22
TLP3502(N)	TLP3502(F)	20
TLP3502A(N)	TLP3502A(F)	20
TLP3503(N)	TLP3503(C,F)	20
TLP3506(N)	TLP3506(F)	20
TLP3507(N)	TLP3507(C,F)	20
TLP351	TLP351(F)	22
TLP3520A		20
TLP3520(N)	TLP3520(F)	20
TLP3521(N)	TLP3521(C,F)	20
TLP3526(N)	TLP3526(F)	20
TLP3527(N)	TLP3527(C,F)	20
TLP3530		20
TLP3540	TLP3540(F)	31
TLP3542	TLP3542(F)	31
TLP3550	TLP3550(F)	
TLP360J	TLP360J(F)	18
TLP3616	TLP3616(F)	20
TLP3617	TLP3617(C,F)	20
TLP361J	TLP361J(F)	18
TLP363J	TLP363J(F)	18







previous Version	Pb-free Version	Page
TLP371	TLP371(F)	16
TLP372	TLP372(F)	16
TLP373	TLP373(F)	16
TLP3904		25
TLP3914		25
TLP3924		25
TLP4006G	TLP4006G(F)	32
TLP4007G	TLP4007G(F)	32
TLP4026G	TLP4026G(F)	32
TLP4027G	TLP4027G(F)	32
TLP4172G	TLP4172G(F)	32
TLP4176G	TLP4176G(F)	32
TLP4192G	TLP4192G(F)	32
TLP4197G	TLP4197G(F)	32
TLP4202G	TLP4202G(F)	32
TLP4206G	TLP4206G(F)	32
TLP421	TLP421	12
TLP4222G	TLP4222G(F)	32
TLP4222G-2	TLP4222G-2(F)	33
TLP4227G	TLP4227G(F)	33
TLP4227G-2	TLP4227G-2(F)	33
TLP4592G	TLP4592G(F)	33
TLP4597G	TLP4597G(F)	33
TLP504A	TLP504A(F)	12
TLP504A-2	TLP504A-2(F)	12
TLP512		22
TLP513		22
TLP521-1	TLP521-1(F)	12
TLP521-2	TLP521-2(F)	12
TLP521-3	TLP521(F) x3	
TLP521-4	TLP521-4(F)	12
TLP523	TLP523(F)	16
TLP523-2	TLP523-2(F)	16
TLP523-3	TLP523(F) x3	
TLP523-4	TLP523-4(F)	16
TLP525G	TLP525G(F)	18
TLP525G-2	TLP525G-2(F)	18
TLP525G-4	TLP525G-4(F)	18
TLP531	TLP531(F)	12
TLP532	TLP532(F)	12
TLP535(SHORT)	TLP535(SHORT,F)	
TLP550	TLP550(F)	22
TLP551		22
TLP552		23
TLP553		23
TLP554		23
TLP555		23
TLP557	TLP557(F)	23
TLP558	TLP558(F)	23
TLP559		23
TLP559(IGM)		23
TLP560G	TLP560G(F)	19
TLP560J	TLP560J(F)	19
TLP561G	TLP561G(C,F)	19







previous Version	Pb-free Version	Page
TLP561J	TLP561J(C,F)	19
TLP570	TLP570(F)	
TLP571	TLP571(F)	
TLP572	TLP572(F)	
TLP590B	TLP590B(C,F)	25
TLP591B	TLP591B(C,F)	25
TLP592A	TLP592A(F)	29
TLP592G	TLP592G(F)	29
TLP594G	TLP594G(F)	29
TLP594GA	TLP594GA(F)	
TLP595A	Discontinued	
TLP595B	Discontinued	
TLP595G	Discontinued	
TLP596A	Discontinued	
TLP596B	Discontinued	
TLP596G	Discontinued	
TLP597A	TLP597A(F)	29
TLP597G	TLP597G(F)	29
TLP597GA	TLP597GA(F)	29
TLP597J	TLP597J(F)	
TLP598A	TLP598AA(F)	
TLP598AA	TLP598AA(F)	29
TLP598B	TLP798GA(F)	
TLP598G	TLP798GA(F)	
TLP598GA	TLP598GA(F)	29
TLP599A	TLP598AA(F)	
TLP599B	TLP598GA(F)	
TLP599G	TLP598GA(F)	
TLP620	TLP620(F)	13
TLP620-2	TLP620-2(F)	13
TLP620-3	TLP620(F) x3	
TLP620-4	TLP620-4(F)	13
TLP621	TLP621(F)	13
TLP621-2	TLP621-2(F)	13
TLP621-3	TLP621(F) x3	
TLP621-4	TLP621-4(F)	13
TLP624	TLP624(F)	13
TLP624-2	TLP624-2(F)	13
TLP624-3	TLP624(F) x3	
TLP624-4	TLP624-4(F)	13
TLP626	TLP626(F)	13
TLP626-2	TLP626-2(F)	14
TLP626-3	TLP626(F) x3	
TLP626-4	TLP626-4(F)	14
TLP627	TLP627(F)	
TLP627-2	TLP627-2(F)	
TLP627-3	TLP627(F) x3	
TLP627-4	TLP627-4(F)	
TLP628	TLP628(F)	14
TLP628-2	TLP628-2(F)	14
TLP628-3	TLP628(F) x3	
TLP628-4	TLP628-4(F)	14
TLP629	TLP629(F)	14
TLP629-2	TLP629-2(F)	14

previous Version	Pb-free Version	Page
TLP629-3	TLP629(F) x3	
TLP629-4	TLP629-4(F)	14
TLP630	TLP630(F)	14
TLP631	TLP631(F)	14
TLP632	TLP632(F)	14
TLP641G	TLP641G(F)	
TLP641J	TLP641J(F)	
TLP645G	TLP741G(F)	
TLP645J	TLP741J(F)	
TLP650	TLP650(F)	
TLP651	TLP651(F)	23
TLP665G(S)	TLP665G(S,F)	
TLP665J(S)	TLP665J(S,F)	
TLP666G(S)	TLP666G(S,C,F)	
TLP666J	TLP666J(S,C,F)	
TLP668J	TLP668J(S,C,F)	
TLP701	TLP701(F)	23
TLP702	TLP702(F)	
TLP705	TLP705(F)	23
TLP706	TLP706(F)	
TLP716	TLP716(F)	
TLP719	TLP719(F)	24
TLP721	TLP721(F)	
TLP722	TLP722(F)	
TLP731	TLP731(F)	
TLP732	TLP732(F)	
TLP733	TLP733(F)	15
TLP734	TLP734(F)	15
TLP741G	TLP741G(F)	17
TLP741J	TLP741J(F)	17
TLP747G	TLP747G(F)	17
TLP747J	TLP747J(F)	17
TLP750	TLP750(F)	24
TLP751	TLP751(F)	24
TLP759	TLP759(F)	24
TLP759(IGM)		24
TLP761G	TLP761G(S,C,F)	
TLP762J	TLP762J(F)	19
TLP763J	TLP763J(S,C,F)	19
TLP794G	TLP794G(F)	
TLP794GA	TLP794GA(F)	
TLP795G	Discontinued	
TLP796G	Discontinued	
TLP797G	TLP797G(F)	
TLP797GA	TLP797GA(F)	29
TLP797GAF	TLP797GAF(F)	29
TLP797J	TLP797J(F)	29
TLP797JF	TLP797JF(F)	29
TLP798G	TLP798GA(F)	
TLP798GA	TLP798GA(F)	29

Pls notice: Pb-free parts are RoHS compliant

3 Recommended Products

Package		SSOP4	SOP4	SOP16	2.54SOP4	2.54SOP6	2.54SOP8
Appearance							
Page for package dimensions							
Output type	Transistor		TLP280 TLP281 TLP283	TLP280-4 TLP281-4 TLP283-4			
	Darlington transistor						
	Thyristor						
	Triac						
	AC power						
	IC						
	Photovoltaic	TLP3904 TLP3914 TLP3924					
	Photorelay	TLP3213 TLP3214 TLP3215 TLP3216 TLP3217 TLP3230 TLP3231	TLP3122		TLP176A, TLP172A TLP176D, TLP172G TLP176G, TLP179D TLP3113 TLP3114 TLP3115 TLP3116 TLP3121 TLP3122 TLP3130 TLP3131 TLP4172G TLP4176G	TLP197A TLP197G TLP192A TLP192G TLP199D TLP3120 TLP4192G TLP4197G	TLP200D TLP206A TLP206G TLP202A TLP202G TLP209D TLP3125 TLP4026G TLP4027G TLP4202G TLP4206G

MFSOP6	SDIP	DIP4	DIP6	DIP8	DIP16	Page for product features
						
TLP180 TLP181 TLP124 TLP126 TLP130 TLP131 TLP137		TLP320 TLP321 TLP421 TLP521-1 TLP620 TLP621 TLP624 TLP626 TLP628 TLP629	TLP330 TLP331 TLP332 TLP531 TLP532 TLP630 TLP631 TLP632 TLP731 TLP732	TLP320-2 / 321-2 TLP521-2 / 620-2 TLP621-2 / 624-2 TLP626-2 / 628-2 TLP629-2	TLP320-4 / 321-4 TLP521-4 / 620-4 TLP621-4 / 624-4 TLP626-4 / 628-4 TLP629-4	p. 10 – 15
TLP127		TLP523 TLP627	TLP371 TLP372 TLP373 TLP570 TLP571 TLP572	TLP523-2 TLP627-2	TLP523-4 TLP627-4	p. 16
TLP141G			TLP541G TLP545J TLP641G / 641J TLP741G / 741J	TLP511GA TLP542G TLP543J TLP611J		p. 17
TLP160G / 160J TLP161G / 161J TLP165J / 166J TLP168J TLP260J TLP261J		TLP525G TLP360J TLP361J TLP363J	TLP560G / 560J TLP561G / 561J TLP3022(S) / 3052(S) TLP3042(S) / 3062(S) TLP3063(S) TLP762J / 763J	TLP525G-2	TLP525G-4	p. 18 – 19
TLP3904 TLP3914 TLP3924				TLP3502 / 3502A TLP3503 TLP3506 / 3507 TLP3616 / 3617	TLP3520 / 3520A TLP3521 TLP3526 / 3527 TLP3530	p. 20
TLP102 TLP106 TLP112 / 112A TLP113 TLP114A TLP115 / 115A TLP116	TLP701 TLP702 TLP705 TLP706 TLP719 TLP716			TLP250 TLP251 TLP351 TLP350 TLP550 TLP557 TLP558 TLP559 TLP651 TLP750 TLP751 TLP759 TLP2200 TLP2530 TLP2531 TLP2601 TLP2630 TLP2631 6N136 6N137 6N139		p. 21 – 24
TLP190B TLP191B			TLP590B TLP591B			p. 25
TLP3110 TLP3111		TLP224G TLP225A TLP227A TLP227G TLP227GA TLP222A TLP222G TLP4222G TLP4227G	TLP594G TLP592A / 597A TLP592G / 597G TLP597GA TLP797GA TLP797GAF TLP798G TLP3542 TLP4597G TLP4592G	TLP224G-2 TLP227A-2 TLP227G-2 TLP227GA-2 TLP3540 TLP222A-2 TLP222G-2 TLP4006G TLP4007G TLP4222G-2 TLP4227G-2		p. 26 – 33

4 Selection Guide

4.1 Transistor Output

Part Number	Pin Configuration	Features	CTR				V _{CEO} (V)	BV _s 1 Minute (Vrms)	Safety Standards ⁽²⁾				
			Rank	Min (%)	Max (%)	@I _F / V _{CE} (mA) (V)			UL	TÜV	VDE	BSI	IEC
TLP124		Mini-flat 6-pin MFSOP Low input drive current	-	100	1200	1/0.5	80	3750	○				
TLP126		Mini-flat 6-pin MFSOP AC input Low input drive current	-	100	1200	±1/0.5			○				
TLP130		Mini-flat 6-pin MFSOP AC input Internal base connection	-	50	600	±5/5			○				
TLP131		Mini-flat 6-pin MFSOP General-purpose Internal base connection	-	50	600	5/5			○				
TLP137		Mini-flat 6-pin MFSOP Low input drive current Internal base connection	-	100	1200	1/0.5			○				
TLP180		Mini-flat 6-pin MFSOP AC input SEMKO-approved	-	50	600	±5/5			○	○ ⁽¹⁾	△	◇ EN 60950 EN 60065	△ 60950 60065
TLP181		Mini-flat 6-pin MFSOP General-purpose High CTR SEMKO-approved	-	50	600	5/5			○		○ ⁽¹⁾	◇ EN 60950 EN 60065	60950 60065
			GB	100	600								
			Y	50	150								
			GR	100	300								
			BL	200	600								
			YH	75	150								
			GRL	100	200								
			GRH	150	300								
TLP280		4-pin SOP Lead pitch: 1.27 mm AC input SEMKO-approved	-	50	600	±5/5	2500	○	○ ⁽¹⁾	◇ EN 60950 EN 60065	△ 60950 60065		
			GB	100	600								
TLP280-4		16-pin SOP 4-channel version of the TLP280 Lead pitch: 1.27 mm AC input SEMKO-approved	-	50	600	±5/5	2500	○	○ ⁽¹⁾	◇ EN 60950 EN 60065	△ 60950 60065		
			GB	100	600								

Note (1): The EN60747-5-2 safety standard for compact packages is different from that for standard DIP packages.







Since the mini-flat package is a compact package, please contact your nearest Toshiba sales representative for more details.

Note (2): Legend in the Safety Standards column:

○: Approved ◇: SELV-approved △: Design which meets safety standard (as of 06/05)

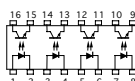
TÜV and VDE: EN60747-5-2-approved with option V4.

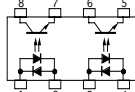
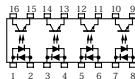
4.1 Transistor Output (continued)

Part Number	Pin Configuration	Features	CTR				V _{CEO} (V)	BVs 1 Minute (Vrms)	Safety Standards ⁽²⁾				
			Rank	Min (%)	Max (%)	@I _F / V _{CE} (mA) (V)			UL	TÜV	VDE	BSI	IEC
TLP281		4-pin SOP Lead pitch: 1.27 mm General-purpose SEMKO-approved	-	50	600	5/5	80	○	○ ⁽¹⁾	◇ EN 60950 EN 60065	△ 60950 60065		
			GB	100									
			Y	50	150								
			GR	100	300								
			BL	200	600								
			YH	75	150								
			GRL	100	200								
			GRH	150	300								
			BLL	200	400								
TLP281-4		16-pin SOP 4-channel version of the TLP281 Lead pitch: 1.27 mm SEMKO-approved	-	50	600	5/5	2500	○	○ ⁽¹⁾	◇ EN 60950 EN 60065	△ 60950 60065		
			GB	100									
TLP283		4-pin SOP Lead pitch: 1.27 mm Low input drive current High-speed switching	-	100	400	1/5	100	○					
TLP283-4		16-pin SOP 4-channel version of the TLP283 Lead pitch: 1.27 mm Low input drive current High-speed switching											
TLP320		4-pin DIP High input current AC input I _F = 150 mA	-	20									
TLP320-2		8-pin DIP Dual channel version of the TLP320	-	20	80	±100/1	55	5000	○	◇ EN 60950 EN 60065	△ 60950 60065		
TLP320-4		16-pin DIP 4-channel version of the TLP320	-	20									
TLP330		6-pin DIP High input current AC input I _F = 150 mA	-	20	80	±100/1	55	5000	○				

Note (1): The EN60747-5-2 safety standard for compact packages is different from that for standard DIP packages.

Since the mini-flat package is a compact package, please contact your nearest Toshiba sales representative for more details.

Note (2): Legend in the Safety Standards column:

○: Approved ◇: SELV-approved △: Design which meets safety standard (as of 06/05)

TÜV and VDE: EN60747-5-2-approved with option V4.

4 Selection Guide

4.1 Transistor Output (continued)

Part Number	Pin Configuration	Features	CTR				V _{CEO} (V)	BV _s 1 Minute (Vrms)	Safety Standards ⁽²⁾				
			Rank	Min (%)	Max (%)	@I _F / V _{CE} (mA) (V)			UL	TÜV	VDE	BSI	IEC
TLP331		6-pin DIP Low input drive current Internal base connection	-	100	1200	1/0.5	55	5000	○				
			BV	200									
TLP332		6-pin DIP Low input drive current No internal base connection	-	100	1200	1/0.5	55	5000	○				
			BV	200									
TLP421 TLP421F		4-pin DIP High isolation voltage UL-approved (double protection) EN60747-approved with option (D4) SEMKO-approved	-	50	600	5/5	80	5000	○	EN 60747	◇ EN 60747	◇ EN 60065 EN 60950	△ 60065 60950
			GB	100									
			BL	200									
			GR	100									
			Y	50									
			YH	75									
			GRL	100									
			GRH	150									
			BLL	200									
TLP504A TLP504A-2		8-pin DIP General-purpose	-	50	600	5/5	55	2500	○				
			GB	100									
TLP521-1		4-pin DIP General-purpose	A	50	600	5/5	55	2500	○				
			GB	100									
			Y	50									
			GR	100									
			BL	200									
TLP521-2		8-pin DIP Dual channel version of the TLP521-1	A	50	600	5/5	55	2500	○				
			GB	100									
TLP521-4		16-pin DIP 4-channel version of the TLP521-1	A	50	600	5/5	55	2500	○				
			GB	100									
TLP531 ⁽³⁾		6-pin DIP General-purpose Internal base connection	A	50	600	5/5	55	2500	○				
			GB	100									
			BL	200									
			GR	100									
			Y	50									
TLP532 ⁽³⁾		6-pin DIP General-purpose High EMI immunity No internal base connection	A	50	600	5/5	55	2500	○				
			GB	100									
			BL	200									
			GR	100									
			Y	50									

Note (2): Legend in the Safety Standards column:

○: Approved ◇: SELV-approved △: Design which meets safety standard (as of 06/05)
TÜV and VDE: EN60747-5-2-approved with option V4.

Note (3): The products with the ranks Y and BL are limited in production. For details, please contact your nearest Toshiba sales representative.

4.1 Transistor Output (continued)

Part Number	Pin Configuration	Features	CTR				V _{CEO} (V)	BVs 1 Minute (Vrms)	Safety Standards ⁽²⁾				
			Rank	Min (%)	Max (%)	@I _F / V _{CE} (mA) (V)			UL	TÜV	VDE	BSI	IEC
TLP620 TLP620F		4-pin DIP AC input EN60747-approved with option (D4) SEMKO-approved	-	50	600	±5/5	55		○	△ EN 60747	◇ EN 60747	◇ EN 60065 EN 60950	△ 60065 60950
GB	100												
TLP620-2		8-pin DIP Dual channel version of the TLP620 EN60747-approved with option (D4) SEMKO-approved	-	50	600	±5/5	55	○	△ EN 60747	◇ EN 60747	◇ EN 60065 EN 60950	△ 60065 60950	
GB	100												
TLP620-4		16-pin DIP 4-channel version of the TLP620 EN60747-approved with option (D4)	-	50	600			○	△ EN 60747	◇ EN 60747	◇ EN 60065 EN 60950	△ 60065 60950	
GB	100												
TLP621 TLP621F		4-pin DIP High isolation voltage UL-approved (double protection) EN60747-approved with option (D4) SEMKO-approved	-	50	600	5/5	55	○	△ EN 60747	△ EN 60747	◇ EN 60065 EN 60950	△ 60065 60950	
GB	100	600											
Y	50	150											
GR	100	300											
BL	200	600											
TLP621-2		8-pin DIP Dual channel version of the TLP621 EN60747-approved with option (D4) SEMKO-approved	-	50	600	5/5	55	○	△ EN 60747	△ EN 60747	◇ EN 60065 EN 60950	△ 60065 60950	
GB	100												
TLP621-4		16-pin DIP 4-channel version of the TLP621 EN60747-approved with option (D4)	-	50	600	5/5	55	○	△ EN 60747	△ EN 60747	◇ EN 60065 EN 60950	△ 60065 60950	
GB	100												
TLP624		4-pin DIP Low input drive current BSI-approved	-	100	200			○	△ EN 60747	△ EN 60747	◇ EN 60065 EN 60950	△ 60065 60950	
BV	200												
TLP624-2		8-pin DIP Dual channel version of the TLP624 BSI-approved	-	100	200	1200	1/0.5	55	○	△ EN 60747	△ EN 60747	◇ EN 60065 EN 60950	△ 60065 60950
BV	200												
TLP624-4		16-pin DIP 4-channel version of the TLP624 BSI-approved	-	100	200	1200	1/0.5	55	○	△ EN 60747	△ EN 60747	◇ EN 60065 EN 60950	△ 60065 60950
BV	200												
TLP626		4-pin DIP Low input drive current AC input BSI-approved	-	100	200	1200	±1/0.5	55	○	△ EN 60747	△ EN 60747	◇ EN 60065 EN 60950	△ 60065 60950
BV	200												

Note (2): Legend in the Safety Standards column:

○: Approved ◇: SELV-approved △: Design which meets safety standard (as of 06/05)

TÜV and VDE: EN60747-5-2-approved with option V4.

4 Selection Guide

4.1 Transistor Output (continued)

Part Number	Pin Configuration	Features	CTR				V _{CEO} (V)	BV _s 1 Minute (Vrms)	Safety Standards ⁽²⁾				
			Rank	Min (%)	Max (%)	@I _F / V _{CE} (mA) (V)			UL	TÜV	VDE	BSI	IEC
TLP626-2		8-pin DIP Dual channel version of the TLP626 BSI-approved	-	100	1200	±1/0.5	55	5000	○	△ EN 60747	△ EN 60747	◇ EN 60065 EN 60950	△ 60065 60950
			BV	200									
TLP626-4		16-pin DIP 4-channel version of the TLP626 BSI-approved	-	100									
			BV	200									
TLP628		4-pin DIP High V _{CEO} V _{CEO} = 350 V	-	50	600	5/5	350						
			GB	100									
TLP628-2		8-pin DIP Dual channel version of the TLP628	-	50					○	△ EN 60747	△ EN 60747	△ EN 60065 EN 60950	△ 60065 60950
			GB	100									
TLP628-4		16-pin DIP 4-channel version of the TLP628	-	50									
			GB	100									
TLP629		4-pin DIP High input current I _F = 150 mA DC input											
TLP629-2		8-pin DIP Dual channel version of the TLP629	-	20	80	100/1	55		○	△ EN 60747	△ EN 60747	△ EN 60065 EN 60950	△ 60065 60950
TLP629-4		16-pin DIP 4-channel version of the TLP629											
TLP630		6-pin DIP AC input High isolation voltage	-	50	600	±5/5	55	○					
			GB	100									
TLP631		6-pin DIP General-purpose Internal base connection	-	50	600	5/5	55						
			GB	100									
			GR	100	300								
TLP632		6-pin DIP General-purpose High EMI immunity No internal base connection	-	50	600	5/5	55	○					
			GB	100									
			GR	100	300								

Note (2): Legend in the Safety Standards column:

○: Approved ◇: SELV-approved △: Design which meets safety standard (as of 06/05)

TÜV and VDE: EN60747-5-2-approved with option V4.

4.1 Transistor Output (continued)

Part Number	Pin Configuration	Features	CTR				V _{CEO} (V)	BV _s 1 Minute (Vrms)	Safety Standards ⁽²⁾				
			Rank	Min (%)	Max (%)	@I _F / V _{CE} (mA) (V)			UL	TÜV	VDE	BSI	IEC
TLP733 TLP733F		6-pin DIP EN60747-approved with option (D4) SEMKO-approved	-	50	600	5/5	55	4000	○	△ EN 60747	◇ EN 60747	◇ EN 60065 EN 60950	△ 60065 60950
		GB	100	300									
		GR	100	300									
TLP734 TLP734F		6-pin DIP EN60747-approved with option (D4) SEMKO-approved No internal base connection	-	50	600								
		GB	100	300									
		GR	100	300									

Note (2): Legend in the Safety Standards column:

○: Approved ◇: SELV-approved △: Design which meets safety standard (as of 06/05)
TÜV and VDE: EN60747-5-2-approved with option V4.

4 Selection Guide

4.2 Darlington Transistor Output

Part Number	Pin Configuration	Features	CTR		V _{CE(sat)}		V _{CE0} (V)	BVs 1 Minute (Vrms)	Safety Standards ⁽²⁾					
			Min (%)	@I _F / V _{CE} (mA) (V)	Max (V)	@I _C / I _F (mA)			UL	TÜV	VDE	BSI	IEC	
TLP127		Mini-flat 6-pin MFSOP High V _{CE0}	1000	1/1	1.2	100/10	300	2500	○	○ ⁽¹⁾	△	◇ EN 60950 EN 60065	△ 60950 60065	
TLP371		6-pin DIP High V _{CE0} SEMKO-approved	1000	1/1	1.2	100/10	300	5000	○					
TLP372		6-pin DIP High V _{CE0} No internal base connection												
TLP373		6-pin DIP High V _{CE0} Large emitter-collector distance												
TLP523		4-pin DIP General-purpose	500	1/1	1.0	50/10	55	2500	○					
TLP523-2		8-pin DIP Dual channel version of the TLP523												
TLP523-4		16-pin DIP 4-channel version of the TLP523												
TLP570		6-pin DIP General-purpose High EMI immunity	1000	1/1	1.2	100/10	35	2500	○					
TLP627		4-pin DIP High V _{CE0} BSI-approved SEMKO-approved	1000	1/1	1.2	100/10	300	5000	○			◇ EN 60747 60747	◇ EN 60065 EN 60950	△ 60065 60950
TLP627-2		8-pin DIP Dual channel version of the TLP627 BSI-approved SEMKO-approved												
TLP627-4		16-pin DIP 4-channel version of the TLP627 BSI-approved												

Note (1): The EN60747-5-2 safety standard for compact packages is different from that for standard DIP packages.





Since the mini-flat package is a compact package, please contact your nearest Toshiba sales representative for more details.

Note (2): Legend in the Safety Standards column:

○: Approved ◇: SELV-approved △: Design which meets safety standard (as of 06/05)

TÜV and VDE: EN60747-5-2-approved with option V4.

4.3 Thyristor Output

Part Number	Pin Configuration	Features	I _{FT}		V _{TM}		V _{DRM} (V)	BV _s 1 Minute (Vrms)	Safety Standards (2)				
			Max (mA)	Max (V)	@I _{TM} (mA)	UL			TÜV	VDE	BSI	IEC	
TLP141G		Mini-flat 6-pin MFSOP General-purpose	10	1.3	100	400	2500	○					
TLP741G TLP741J		6-pin DIP VDE0884-approved with option (D4)	10	1.3	100	400 600	4000	○	△ VDE 0884	◇ 0884	◇ EN 60065 EN 60950	△ 435 ⁽³⁾ 950	
TLP747G TLP747GF		6-pin DIP EN60747-approved with option (D4) Internal creepage: 4 mm (min) SEMKO-approved	15	1.3	100	400 600		○	△ EN 60747	◇ EN 60747	◇ EN 60065 EN 60950	△ 60950	
TLP747J TLP747JF													

Note (2): Legend in the Safety Standards column:

○: Approved ◇: SELV-approved △: Design which meets safety standard (as of 06/05)

TÜV and VDE: EN60747-5-2-approved with option V4.

Note (3): Only applied to the TLP741G (LF2)/J(LF2)

4 Selection Guide

4.4 Triac Output

Part Number	Pin Configuration	Features	IFT		V _{TM}		V _{DRM} (V)	BV _s 1 Minute (Vrms)	Safety Standards (2)								
			Rank	Max (mA)	Max (V)	@I _{TM} (mA)			UL	TÜV	VDE	BSI	IEC				
TLP160G		Mini-flat 6-pin MFSOP Non-zero cross	—	10	2.8	70	400	2500	○	△ ⁽¹⁾	○ ⁽¹⁾						
TLP165J			IFT7	7													
TLP160J			IFT5	5													
TLP161G		Mini-flat 6-pin MFSOP Zero cross	—	10			2.8		70	400	2500	○	△ ⁽¹⁾	○ ⁽¹⁾			
TLP166J			IFT7	7													
TLP161J			IFT5	5													
TLP168J			—	10													
			IFT7	7													
TLP260J		Mini-flat 6-pin MFSOP Non-zero cross	—	10	2.8	70	600	3000	○	△ ⁽¹⁾	○ ⁽¹⁾						
TLP360J		4-pin DIP EN60747-approved with option (D4) Non-zero cross	—	10	2.8	70	600	5000	○	◇ EN 60747	△						
TLP360JF			IFT7	7													
TLP361J		4-pin DIP EN60747-approved with option (D4) Zero cross	—	10	2.8	70	600	5000	○	◇ EN 60747	△						
TLP361JF			IFT7	7													
TLP363J		4-pin DIP EN60747-approved with option (D4) Zero cross High impulse noise immunity	—	10	2.8	70	600	5000	○	◇ EN 60747	△						
TLP363JF			IFT7	7													
TLP525G		4-pin DIP	—	10	3.0	100	400	2500	○								
TLP525G-2		8-pin DIP Dual channel version of the TLP525G	—	10													
TLP525G-4		16-pin DIP 4-channel version of the TLP525G	—	10													

Note (1): The EN60747-5-2 safety standard for compact packages is different from that for standard DIP packages.

Since the mini-flat package is a compact package, please contact your nearest Toshiba sales representative for more details.

Note (2): Legend in the Safety Standards column:

○: Approved ◇: SELV-approved △: Design which meets safety standard (as of 06/05)

TÜV and VDE: EN60747-5-2-approved with option V4.

4.4 Triac Output (continued)

Part Number	Pin Configuration	Features	IFT		V _{TM}		V _{DRM} (V)	BV _s 1 Minute (Vrms)	Safety Standards (2)					
			Rank	Max (mA)	Max (V)	@ITM (mA)			UL	TÜV	VDE	BSI	IEC	
TLP560G		6-pin DIP General-purpose Non zero cross	—	10			400	2500	○					
TLP560J			IFT7	7										600
			IFT5	5	3.0	100								
TLP561G		6-pin DIP General-purpose Zero cross	—	10			400	2500	○					
TLP561J			IFT7	7										600
			IFT5	5	3.0	100								
			—	10										
			IFT7	7										
TLP3022(S)		6-pin DIP EN60747-approved with option (D4) SEMKO-approved Non-zero cross	—	10	3.0	100	400	5000	○	△ EN 60747	◇ EN 60747	◇ EN 60065 EN 60950	△ 60950 60065	
TLP3052(S)			IFT7	7	3.0	100								600
TLP3052F(S)														
TLP3042(S)		6-pin DIP EN60747-approved with option (D4) SEMKO-approved Zero cross	—	10	3.0	100	400	5000	○	△ EN 60747	◇ EN 60747	◇ EN 60065 EN 60950	△ 60950 60065	
TLP3042F(S)			—	5										
TLP3043(S)			IFT7	7	3.0	100								600
TLP3043F(S)														
TLP3062(S)														
TLP3062F(S)														
TLP3063(S)		6-pin DIP EN60747 approved with option (D4) Low trigger current SEMKO-approved Zero cross	—	3	3.0	100	600	5000	○	△ EN 60747	◇ EN 60747	◇ EN 60065 EN 60950	△ 60950 60065	
TLP3063F(S)			IFT7	7	3.0	100								600
TLP3064(S)														
TLP3064F(S)														
TLP762J		6-pin DIP Internal creepage: 4 mm (min) EN60747-approved with option (D4) SEMKO-approved Non-zero cross	—	10	3.0	100	600	4000	○	△ EN 60747	◇ EN 60747	◇ EN 60065 EN 60950	△ 60950 60065	
TLP762JF			IFT7	7	3.0	100								600
TLP763J		6-pin DIP Internal creepage: 4 mm (min) EN60747-approved with option (D4) SEMKO-approved Zero cross	—	10	3.0	100	600	4000	○	△ EN 60747	◇ EN 60747	◇ EN 60065 EN 60950	△ 60950 60065	
TLP763JF			IFT7	7	3.0	100								600

Note (1): The EN60747-5-2 safety standard for compact packages is different from that for standard DIP packages.

Since the mini-flat package is a compact package, please contact your nearest Toshiba sales representative for more details.

Note (2): Legend in the Safety Standards column:

○: Approved ◇: SELV-approved △: Design which meets safety standard (as of 06/05)

TÜV and VDE: EN60747-5-2-approved with option V4.

4 Selection Guide

4.5 AC Power Output

Part Number	Pin Configuration	Features	IFT		I _{TM} (Arms)		V _{DRM} (V)	BV _s 1 Minute (Vrms)	Safety Standards (2)				
			Rank	Max (mA)	@Ta = 40°C				UL	TÜV	VDE	BSI	IEC
TLP3502		8-pin DIP Direct control of a load of up to 0.5 Arms	—	10	0.5		400	○					
TLP3503			IFT7	7									
			IFT5	5									
The TLP3503 offers a ZC version.													
TLP3520		16-pin DIP Direct control of a load of up to 1 Arms	—	10	1		600	○					
TLP3521			IFT7	7									
			IFT5	5									
The TLP3521 offers a ZC version.													
TLP3506		8-pin DIP Direct control of a load of up to 0.5 Arms High VDRM	—	10	0.5		400	○					
TLP3507													
The TLP3507 offers a ZC version.													
TLP3526		16-pin DIP Direct control of a load of up to 1 Arms High VDRM	—	10	1		600	○	◇	EN 60747	△		
TLP3527													
The TLP3527 offers a ZC version.													
TLP3502A		8-pin DIP Direct control of a load of up to 0.6 Arms Non-zero cross	—	10	0.6		400	○					
			IFT7	7									
			IFT5	5									
TLP3520A		16-pin DIP Direct control of a load of up to 1.2 Arms Non-zero cross	—	10	1.2		400	○					
			IFT7	7									
			IFT5	5									
TLP3530		16-pin DIP Dual channel Direct control of a load of up to 1.0 Arms (for 1ch) or 1.4 Arms load (for 2 ch) Non-zero cross	—	10	1 [For 1channel] 1.4 [For two channels]		400	○					
TLP3616		8-pin DIP Direct control of a load of up to 1 Arms High VDRM	—	10	1 (1.2 @Ta = 25°C)		600	△	◇	EN 60747			
TLP3617													
The TLP3617 offers a ZC version.													

Note (2): Legend in the Safety Standards column:

○: Approved ◇: SELV-approved △: Design which meets safety standard (as of 06/05)
TÜV and VDE: EN60747-5-2-approved with option D4.

4.6 IC Output

Part Number	Pin Configuration	Features	Data Rate (Typ. @ NRZ)	CTR	@I _F (I _N) (mA)	BV _s 1 Minute (Vrms)	Safety Standards ⁽²⁾				
							UL	TÜV	VDE	BSI	IEC
6N135		JEDEC-compliant High-speed	1 Mbits/s	7% min	16	2500	○				
6N136				19% min							
6N137		JEDEC-compliant High-speed	10 Mbits/s	700% typ.	5		○				
6N138		JEDEC-compliant High CTR High-speed	300 Kbits/s	300% min	1.6		○				
6N139				400% min							
TLP102		Mini-flat 6-pin MFSOP Inverter logic High CMR	250 ns	Totem-pole output	3	3750	△				
TLP106		Mini-flat 6-pin MFSOP Buffer logic High CMR	250 ns	Totem-pole output	3						
TLP112		Mini-flat 6-pin MFSOP High-speed, High CMR	1 Mbits/s	10% min	16	2500	○				
TLP112A		Highly sensitive version of the TLP112		20% min							
TLP113		Mini-flat 6-pin MFSOP High-speed Logic output	10 Mbits/s	Open-collector output	10		○				
TLP114A		Mini-flat 6-pin MFSOP High CMR version of the TLP112A	1 Mbits/s	20% min	16	3750	○	○ ⁽¹⁾	△		
TLP114A(IGM)				0.45 μs							
TLP115		Mini-flat 6-pin MFSOP High CMR version of the TLP113	10 Mbits/s	Open-collector output	10	2500	○				
TLP115A		Highly sensitive version of the TLP115									
TLP116		Mini-flat 6-pin MFSOP Ultra-high speed	20 MBd	Totem-pole output	5	3750	○				

Note (1): The EN60747-5-2 safety standard for compact packages is different from that for standard DIP packages.

Since the mini-flat package is a compact package, please contact your nearest Toshiba sales representative for more details.

Note (2): Legend in the Safety Standards column:

○: Approved ◊: SELV-approved △: Design which meets safety standard (as of 06/05)

TÜV and VDE: EN60747-5-2-approved with option V4.

4 Selection Guide

4.6 IC Output (continued)

Part Number	Pin Configuration	Features	Data Rate (Typ. @ NRZ)	CTR	@I _F (I _N) (mA)	BV _s 1 Minute (Vrms)	Safety Standards ⁽²⁾					
							UL	TÜV	VDE	BSI	IEC	
TLP250		8-pin DIP Direct drive of a medium-power IGBT/MOSFET High-speed EN60747-approved with option (D4)	0.15 µs	Peak output current: ±1.5 (max)	5	2500	○	△ EN 60747	◇ EN 60747			
TLP250F		8-pin DIP Direct drive of a medium-power IGBT/MOSFET High-speed EN60747-approved with option (D4)	0.15 µs	Peak output current: ±2.0 (max)	5		○	△ EN 60747	◇ EN 60747			
TLP250(INV)		8-pin DIP Direct drive of a medium-power IGBT/MOSFET High-speed For inverter applications	0.15 µs	Peak output current: ±2.0 (max)	5		○	△ EN 60747	◇ EN 60747			
TLP250F(INV)		8-pin DIP Direct drive of a medium-power IGBT/MOSFET High-speed For inverter applications	0.15 µs	Peak output current: ±2.0 (max)	5		○	△ EN 60747	◇ EN 60747			
TLP251		8-pin DIP Direct drive of a small-power IGBT/MOSFET EN60747-approved with option (D4)	0.25 µs	Peak output current: ±0.4 (max)	5		3750	○	△ EN 60747	◇ EN 60747		
TLP251F		8-pin DIP Direct drive of a small-power IGBT/MOSFET EN60747-approved with option (D4)	0.25 µs	Peak output current: ±0.4 (max)	5			○	△ EN 60747	◇ EN 60747		
TLP350		8-pin DIP Direct drive of a medium-power IGBT/MOSFET High-speed Low power dissipation	0.26 µs	Peak output current: ±2.5 (max)	5	○		△ EN 60747	◇ (4) EN 60747			
TLP350F		8-pin DIP Direct drive of a medium-power IGBT/MOSFET High-speed Low power dissipation	0.26 µs	Peak output current: ±2.5 (max)	5	○		△ EN 60747	◇ (4) EN 60747			
TLP351		8-pin DIP Direct drive of a small-power IGBT/MOSFET High-speed Low power dissipation	0.2 µs	Peak output current: ±0.6 (max)	5	○		◇ EN 60747				
TLP351F		8-pin DIP Direct drive of a small-power IGBT/MOSFET High-speed Low power dissipation	0.2 µs	Peak output current: ±0.6 (max)	5	○		◇ EN 60747				
TLP512		6-pin DIP 6-pin package version of the TLP550	1 Mbits/s	20% min	16	2500	○					
TLP513		6-pin DIP 6-pin package version of the TLP552	10 Mbits/s	Logic output Open-collector	5		○					
TLP550		8-pin DIP No internal base connection High-speed High CMR	1 Mbits/s	10% min (19% (min) for rank O)	16		○					
TLP551		8-pin DIP Internal base connection High-speed	1 Mbits/s	10% min (19% (min) for rank O)	16		○					

Note (2): Legend in the Safety Standards column:

○: Approved ◇: SELV-approved △: Design which meets safety standard (as of 06/05)
TÜV and VDE: EN60747-5-2-approved with option V4.

4.6 IC Output (continued)

Part Number	Pin Configuration	Features	Data Rate (Typ. @ NRZ)	CTR	@I _F (I _N) (mA)	BV _s 1 Minute (Vrms)	Safety Standards ⁽²⁾				
							UL	TÜV	VDE	BSI	IEC
TLP552		8-pin DIP High-speed Logic output	10 Mbits/s	Open-collector	5	2500	○				
TLP553		8-pin DIP High-speed Low input drive current	300 Kbits/s	400% min	0.5		○				
TLP554		8-pin DIP High-speed High CMR version of the TLP552	10 Mbits/s	Open-collector	5		○				
TLP555		8-pin DIP Low input current High-speed High V _{CC} operation	5 Mbits/s	3-state output	1.6		○				
TLP557		8-pin DIP High-speed Direct drive of a power transistor	1 μs	Constant current output: 0.25 A	5		○				
TLP558		8-pin DIP Inverted logic version of the TLP555	5 Mbits/s	3-state output	1.6		○				
TLP559		8-pin DIP High CMR version of the TLP550 No internal base connection	1 Mbits/s	20% min	16		○				
TLP559(GM)			0.45 μs	25% min	10						
TLP651		8-pin DIP High isolation voltage Internal base connection High-speed	1 Mbits/s	10% min (19% (min) for rank O)	16		5000	○			
TLP701		6-pin SDIP Direct drive of a small-power IGBT/MOSFET High-speed Low power dissipation	0.25 μs	Output current: ±0.6 (max)	5		5000	○	◇ EN 60747	△ EN 60747	
TLP701F											
TLP705		6-pin SDIP Direct drive of a small-power IGBT/MOSFET Ultra-high speed Low power dissipation	0.1 μs	Output current: ±0.45 (max)	5	○					
TLP705F											

Note (2): Legend in the Safety Standards column:

○: Approved ◇: SELV-approved △: Design which meets safety standard (as of 06/05)
TÜV and VDE: EN60747-5-2-approved with option V4.

4 Selection Guide

4.6 IC Output (continued)

Part Number	Pin Configuration	Features	Data Rate (Typ. @ NRZ)	CTR	@I _F (I _N) (mA)	BV _s 1 Minute (Vrms)	Safety Standards ⁽²⁾				
							UL	TÜV	VDE	BSI	IEC
TLP719		6-pin SDIP High CMR	1 Mbits/s	20% min	16	16	○	◇ EN 60747	△ EN 60747		
TLP719F											
TLP750		8-pin DIP High isolation voltage High CMR EN60747-approved with option (D4) SEMKO-approved	1 Mbits/s	10% min (19% (min) for rank O)	16	16	○	△ EN 60747	◇ EN 60747	◇ EN 60065 EN 60950	△ 60065 60950
TLP750F											
TLP751		8-pin DIP High isolation voltage Internal base connection EN60747-approved with option (D4) SEMKO-approved	1 Mbitss	10% min	16	5000	○	△ EN 60747	◇ EN 60747	◇ EN 60065 EN 60950	
TLP751F											
TLP759		8-pin DIP IEC950 design stand- ard version of the TLP559 EN60747-approved with option (D4) SEMKO-approved	1 Mbits/s	20% min	16	16	○	△ EN 60747	◇ EN 60747	◇ EN 60065 EN 60950	△ 60065 60950
TLP759F											
TLP759(GM)			0.45 µs	25% min	10						
TLP759F(GM)											
TLP2200		8-pin DIP Low input current High-speed High V _{CC} operation	5 Mbits/s	3-state output	1.6	2500	○				
TLP2530		Dual channel of the 6N135 and the TLP550	1 Mbits/s	7% min	16		○				
TLP2531			1 Mbits/s	19% min	16		○				
TLP2601		8-pin DIP High CMR High-speed	10 Mbits/s	Open-collec- tor output	5	2500	○				
TLP2630		Dual channel of the 6N137 and the TLP552	10 Mbits/s	Open-collec- tor output	5		○				
TLP2631		High CMR Dual channel version of the TLP554	10 Mbits/s	Open-collec- tor output	5		○				

Note (2): Legend in the Safety Standards column:

○: Approved <>: SELV-approved △: Design which meets safety standard (as of 06/05)
TÜV and VDE: EN60747-5-2-approved with option V4.

4.7 Photovoltaic Output

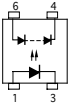
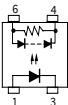
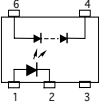
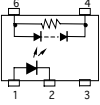
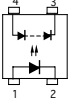
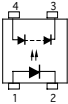
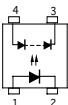
Part Number	Pin Configuration	Features	Short-Circuit Current (μA)			Open Voltage Voc (V)		BV _s 1 Minute (Vrms)	Safety Standards ⁽²⁾				
			Rank	Min	@I _f (mA)	Min	@I _f (mA)		UL	TÜV	VDE	BSI	IEC
TLP190B		Mini-flat 6-pin MFSOP	-	12	10	7	10	2500	○				
TLP191B		Mini-flat 6-pin MFSOP Built-in shunt regulator	-	24	20	7	20		○				
TLP590B		6-pin DIP General-purpose	-	12	10	7	10		○				
			C20	20									
TLP591B		6-pin DIP Built-in shunt regulator	-	24	20	7	20	○					
			C40	40									
TLP3904		4-pin SSOP General-purpose	-	5	10	7	10	1500	△				
TLP3914		4-pin SSOP High output	-	20	10	7	10		△				
TLP3924		4-pin SSOP High output	-	4	10	30	10		△				

Note (2): Legend in the Safety Standards column:

○: Approved ◇: SELV-approved △: Design which meets safety standard (as of 06/05)

4 Selection Guide

4.8 Photorelays (MOSFET Output, 1-Form-A)

Part Number	Pin Configuration	Features	IFT		RON		VOFF(V)	BV _s 1 Minute (Vrms)	Safety Standards ⁽²⁾					
			Rank	Max (mA)	Max (Ω)	@IF (mA)			@ION (A)	UL	TÜV	VDE	BSI	IEC
TLP172A		4-pin SOP Lead pitch: 2.54 mm Low trigger current High output current	—	3	2	5	0.4 [AC]	60	1500	○				
TLP172G		4-pin SOP Lead pitch: 2.54 mm Low trigger current General-purpose	—	3	35	5	0.11 [AC]	350		○				
TLP174G		4-pin SOP Lead pitch: 2.54 mm Current-limiting function	—	3	35	5	0.12 [AC]	350		○				
TLP174GA		Limit current: 150 to 300 mA						400						
TLP176A		4-pin SOP Lead pitch: 2.54 mm Low trigger current High output current	—	3	2	5	0.4 [AC]	60		○	△	○ ⁽¹⁾		
TLP176D		4-pin SOP Lead pitch: 2.54 mm Low trigger current Low On-resistance	—	3	8	5	0.2 [AC]	200		○	△	○ ⁽¹⁾		
TLP176G		4-pin SOP Lead pitch: 2.54 mm Low trigger current General-purpose	—	3	35	5	0.12 [AC]	350		○	△	○ ⁽¹⁾	○ EN 60065 EN 60950	△ 60065 60950
TLP176GA		4-pin SOP Lead pitch: 2.54 mm Low trigger current General-purpose	—	3	35	5	0.12 [AC]	400		○			○ EN 60065 EN 60950	△ 60065 60950
TLP179D		4-pin SOP Lead pitch: 2.54 mm Low trigger current COFF 15 pF (typ.)	—	3	50	5	0.05 [AC]	200		○				
TLP192A		6-pin SOP Lead pitch: 2.54 mm Low trigger current High output current	—	3	2	5	0.4 [AC]	60		○				
TLP192G		6-pin SOP Lead pitch: 2.54 mm Low trigger current General-purpose	—	3	35	5	0.11 [AC]	350		○				
TLP197A		6-pin SOP Lead pitch: 2.54 mm Low trigger current High output current	—	3	2	5	0.4 [AC]	60		○				
TLP197D		6-pin SOP Lead pitch: 2.54 mm Low trigger current Low On-resistance	—	3	8	5	0.2 [AC]	200		○				

Note (1): The EN60747-5-2 safety standard for compact packages is different from that for standard DIP packages.

Since the mini-flat package is a compact package, please contact your nearest Toshiba sales representative for more details.

Note (2): Legend in the Safety Standards column:

○: Approved ◊: SELV-approved △: Design which meets safety standard (as of 06/05)

TÜV and VDE: EN60747-5-2-approved with option V4.

4.8 Photorelays (MOSFET Output, 1-Form-A) (continued)

Part Number	Pin Configuration	Features	IFT		RON		V _{OFF} (V)	BV _s 1 Minute (Vrms)	Safety Standards ⁽²⁾					
			Rank	Max (mA)	Max (Ω)	@I _F (mA)			@I _{ON} (A)	UL	TÜV	VDE	BSI	IEC
TLP197G		6-pin SOP Lead pitch: 2.54 mm Low trigger current General-purpose	—	3	35	5	0.12 [AC]	350	1500	○	△	○ ⁽¹⁾	○ EN 60065 EN 60950	△ 60065 60950
TLP197GA		6-pin SOP Lead pitch: 2.54 mm Low trigger current General-purpose	—	3	35	5	0.12 [AC]	400		○			○ EN 60065 EN 60950	△ 60065 60950
TLP199D		6-pin SOP Lead pitch: 2.54 mm Low trigger current Coff 15 pF (typ.)	—	3	50	5	0.05 [AC]	200		○				
TLP200D		8-pin SOP Lead pitch: 2.54 mm Dual channel version of the TLP176D	—	3	8	5	0.2 [AC]	200		○				
TLP202A		8-pin SOP Lead pitch: 2.54 mm Dual channel version of the TLP172A	—	3	2	5	0.4 [AC]	60		○				
TLP202G		8-pin SOP Lead pitch: 2.54 mm Dual channel version of the TLP172G	—	3	50	5	0.11 [AC]	350		○				
TLP206A		8-pin SOP Lead pitch: 2.54 mm Dual channel version of the TLP176A	—	3	2	5	0.4 [AC]	60		○				
TLP206G		8-pin SOP Lead pitch: 2.54 mm Dual channel version of the TLP176G	—	3	35	5	0.12 [AC]	350		○	△	○ ⁽¹⁾	○ EN 60065 EN 60950	△ 60065 60950
TLP206GA		8-pin SOP Lead pitch: 2.54 mm Dual channel version of the TLP176GA	—	3	35	5	0.12 [AC]	400		○			○ EN 60065 EN 60950	△ 60065 60950
TLP209D		8-pin SOP Lead pitch: 2.54 mm Dual channel version of the TLP179D	—	3	50	5	0.05 [AC]	200		○				
TLP222A		4-pin DIP Low trigger current	—	3	2	5	0.5 [AC]	60	2500	○				
TLP222A-2		8-pin DIP Low trigger current High output current	—	3	2	5	0.5 [AC]	60		○				

Note (1): The EN60747-5-2 safety standard for compact packages is different from that for standard DIP packages.

Since the mini-flat package is a compact package, please contact your nearest Toshiba sales representative for more details.

Note (2): Legend in the Safety Standards column:

○: Approved <>: SELV-approved △: Design which meets safety standard (as of 06/05)

TÜV and VDE: EN60747-5-2-approved with option V4.

4 Selection Guide

4.8 Photorelays (MOSFET Output, 1-Form-A) (continued)

Part Number	Pin Configuration	Features	IFT		RON		VOFF(V)	BVts 1 Minute (Vrms)	Safety Standards ⁽²⁾				
			Rank	Max (mA)	Max (Ω)	@IF (mA)			@ION (A)	UL	TÜV	VDE	BSI
TLP222G		4-pin DIP Low trigger current General-purpose SEMKO-approved	—	3	50	5	0.12 [AC]	350	○			○ EN 60065 EN 60950	△ 60065 60950
TLP222G-2		8-pin DIP Dual channel version of the TLP222G SEMKO-approved	—	3	50	5	0.12 [AC]	350	○			○ EN 60065 EN 60950	△ 60065 60950
TLP224G		4-pin DIP Current-limiting function Limit current: 150 to 300 mA SEMKO-approved	—	3	35	5	0.12 [AC]	350	○			○ EN 60065 EN 60950	△ 60065 60950
TLP224G-2		8-pin DIP Dual channel version of the TLP224G SEMKO-approved	—	3	35	5	0.12 [AC]	350	○			○ EN 60065 EN 60950	△ 60065 60950
TLP225A		4-pin DIP For DC use only	—	5	1.1	10	0.5 [DC]	60	○				△ 60950
TLP227A		4-pin DIP Low trigger current General-purpose SEMKO-approved	—	3	2	5	0.5 [AC]	60	○				△ 60950
TLP227A-2		8-pin DIP Dual channel version of the TLP227A SEMKO-approved	—	3	2	5	0.5 [AC]	60	○				△ 60950
TLP227G		4-pin DIP Low trigger current General-purpose SEMKO-approved	—	3	35	5	0.12 [AC]	350	○	○ EN 60747	△ EN 60747	◇ 60065 EN 60950	△ 60065 60950
TLP227G-2		8-pin DIP Dual channel version of the TLP227G SEMKO-approved	—	3	35	5	0.12 [AC]	350	○	○ EN 60747	△ EN 60747	◇ 60065 EN 60950	△ 60065 60950
TLP227GA		4-pin DIP Low trigger current General-purpose SEMKO-approved	—	3	35	5	0.12 [AC]	400	○				△ 60950
TLP227GA-2		8-pin DIP Dual channel version of the TLP227GA SEMKO-approved	—	3	35	5	0.12 [AC]	400	○	△	○	○	△ 60950

Note (1): The EN60747-5-2 safety standard for compact packages is different from that for standard DIP packages.

Since the mini-flat package is a compact package, please contact your nearest Toshiba sales representative for more details.

Note (2): Legend in the Safety Standards column:

○: Approved ◇: SELV-approved △: Design which meets safety standard (as of 06/05)
TÜV and VDE: EN60747-5-2-approved with option V4.

4.8 Photorelays (MOSFET Output, 1-Form-A) (continued)

Part Number	Pin Configuration	Features	IFT		RON		V _{OFF} (V)	BV _s 1 Minute (Vrms)	Safety Standards ⁽²⁾							
			Rank	Max (mA)	Max (Ω)	@I _F (mA)			@I _{ON} (A)	UL	TÜV	VDE	BSI	IEC		
TLP592A		6-pin DIP Low trigger current High output current	—	3	2	5	0.5 [AC]	60	2500	○						
TLP592G		6-pin DIP Low trigger current General-purpose	—	3	50	5	0.12 [AC]	350		○						
TLP594G		6-pin DIP Current-limiting function Limit current: 150 to 300 mA Low trigger current	—	3	35	5	0.12 [AC]	350		○						
TLP597A		6-pin DIP Low trigger current High output current SEMKO-approved	—	3	2	5	0.5 [AC]	60		○						△ 60950
TLP597G		6-pin DIP Low trigger current General-purpose SEMKO-approved	—	3	35	5	0.12 [AC]	350		○	○ EN 60747	△ EN 60747	◇ EN 60065 EN 60950	△ 60065 60950		
TLP597GA		6-pin DIP Low trigger current General-purpose SEMKO-approved	—	3	35	5	0.12 [AC]	400		○						△ 60950
TLP598AA		6-pin DIP Low trigger current High output current	—	3	2	5	0.5 [AC]	60		△						
TLP598GA		6-pin DIP Low trigger current Low On-resistance	—	3	12	5	0.15 [AC]	400		△						
TLP797GA		6-pin DIP High isolation voltage IEC950-compliant	—	3	35	5	0.12 [AC]	400		△	△		◇ EN 60747			
TLP797GAF		6-pin DIP High isolation voltage	—	3	35	5	0.1 [AC]	600		○	△	△	△	△	△	
TLP797J		6-pin DIP High isolation voltage	—	3	35	5	0.1 [AC]	600	△	△	△	△	△	△		
TLP797JF		6-pin DIP Low trigger current Low On-resistance	—	3	12	5	0.15 [AC]	400	△							
TLP3110		6-pin MFSOP Low CR COFF: 100 pF (Typ.) For measuring instruments	—	4	1.2	5	0.35 [AC]	60	1500	○						

Note (1): The EN60747-5-2 safety standard for compact packages is different from that for standard DIP packages.

Since the mini-flat package is a compact package, please contact your nearest Toshiba sales representative for more details.

Note (2): Legend in the Safety Standards column:

○: Approved ◇: SELV-approved △: Design which meets safety standard (as of 06/05)

TÜV and VDE: EN60747-5-2-approved with option V4.

4 Selection Guide

4.8 Photorelays (MOSFET Output, 1-Form-A) (continued)

Part Number	Pin Configuration	Features	IFT		RON		V _{OFF} (V)	BV _s 1 Minute (Vrms)	Safety Standards ⁽²⁾					
			Rank	Max (mA)	Max (Ω)	@I _F (mA)			@I _{ON} (A)	UL	TÜV	VDE	BSI	IEC
TLP3111		6-pin MFSOP Low CR COFF: 11 pF (Typ.) For measuring instruments	—	4	20	5	0.1 [AC]	80	1500	○				
TLP3113		4-pin SOP Lead pitch: 2.54 mm Ultra-low CR: 10 pF x Ω COFF: 0.6 pF (Typ.) For measuring instruments	—	4	35	5	0.08 [AC]	40		○				
TLP3114		4-pin SOP Lead pitch: 2.54 mm Ultra-low CR: 10 pF x Ω COFF: 5 pF (Typ.) For measuring instruments	—	4	3	5	0.25 [AC]	40		○				
TLP3115		4-pin SOP Lead pitch: 2.54 mm Ultra-low CR: 10 pF x Ω COFF: 10 pF (Typ.) For measuring instruments	—	4	1.5	5	0.3 [AC]	40		○				
TLP3116		4-pin SOP Lead pitch: 2.54 mm Ultra-low CR: 10 pF x Ω COFF: 1 pF (Typ.) For measuring instruments	—	4	15	5	0.12 [AC]	40		○				
TLP3120		6-pin SOP Lead pitch: 2.54 mm Low CR I _{ON} : 1.25 A (Max) For measuring instruments	—	5	0.15	5	1.25 [AC]	80		○				
TLP3121		4-pin SOP Lead pitch: 2.54 mm Low CR: 30 pF x Ω For measuring instruments	—	4	1.2	5	0.35 [AC]	80		○				
TLP3122		4-pin SOP Lead pitch: 2.54 mm High output current I _{ON} : 1 A (max) @T _a : 50°C For measuring instruments	—	3	0.7	5	1 [AC]	60		○				
TLP3125		8-pin SOP Lead pitch: 2.54 mm Low On-resistance Low trigger current For measuring instruments	—	3	4	5	0.2 [AC]	400		○				
TLP3130		4-pin SOP Lead pitch: 2.54 mm Ultra-low CR: 5 pF x Ω COFF: 1 pF (typ.) For measuring instruments	—	4	8	5	0.16 [AC]	20		○				
TLP3131		4-pin SOP Lead pitch: 2.54 mm Ultra-low CR: 5 pF x Ω COFF: 5 pF (typ.) For measuring instruments	—	4	1.5	5	0.3 [AC]	20		○				

Note (2): Legend in the Safety Standards column:

○: Approved ◊: SELV-approved △: Design which meets safety standard (as of 06/05)
TÜV and VDE: EN60747-5-2-approved with option V4.

4.8 Photorelays (MOSFET Output, 1-Form-A) (continued)

Part Number	Pin Configuration	Features	IFT		RON		V _{OFF} (V)	BV _s 1 Minute (Vrms)	Safety Standards ⁽²⁾					
			Rank	Max (mA)	Max (Ω)	@I _F (mA)			@I _{ON} (A)	UL	TÜV	VDE	BSI	IEC
TLP3212		4-pin SSOP Lead pitch: 1.27 mm Ultra-low CR: 20 pF x Ω COFF: 20 pF (typ.) For measuring instruments	—	5	1.5	5	0.4 [AC]	60	1500	△				
TLP3213		4-pin SSOP Lead pitch: 1.27 mm Ultra-low CR: 15 pF x Ω COFF: 0.6 pF (typ.) For measuring instruments	—	4	35	5	0.08 [AC]	40		△				
TLP3214		4-pin SSOP Lead pitch: 1.27 mm Ultra-low CR: 10 pF x Ω COFF: 5 pF (typ.) For measuring instruments	—	4	3	5	0.25 [AC]	40		△				
TLP3215		4-pin SSOP Lead pitch: 1.27 mm Ultra-low CR: 10 pF x Ω COFF: 10 pF (typ.) For measuring instruments	—	4	1.5	5	0.3 [AC]	40		△				
TLP3216		4-pin SSOP Lead pitch: 1.27 mm Ultra-low CR: 10 pF x Ω COFF: 1 pF (typ.) For measuring instruments	—	4	15	5	0.12 [AC]	40		△				
TLP3217		4-pin SSOP Lead pitch: 1.27 mm Low CR COFF: 3.5 pF (typ.) For measuring instruments	—	5	12	10	0.12 [AC]	80		△				
TLP3230		4-pin SSOP Ultra-low CR: 5 pF x Ω COFF: 1 pF (typ.) For measuring instruments	—	4	8	5	0.16 [AC]	20		△				
TLP3231		4-pin SSOP Ultra-low CR: 5 pF x Ω COFF: 5 pF (typ.) For measuring instruments	—	4	1.2	5	0.3 [AC]	20		△				
TLP3540		8-pin DIP Low On-resistance I _{ON} : 2 A (max) Measuring instruments and power lines	—	5	0.12	5	2 [AC]	60		○				
TLP3542		6-pin DIP Low On-resistance I _{ON} : 2.5 A (max) For measuring instruments	—	3	0.1	10	2.5 [AC]	60		2500	△			

Note (2): Legend in the Safety Standards column:

○: Approved <>: SELV-approved △: Design which meets safety standard (as of 06/05)
TÜV and VDE: EN60747-5-2-approved with option V4.

4 Selection Guide

4.9 Photorelays (MOSFET Output, 1-Form-B)

Part Number	Pin Configuration	Features	IFT		RON		V _{OFF} (V)	BV _s 1 Minute (Vrms)	Safety Standards (2)					
			Rank	Max (mA)	Max (Ω)	@IF (mA)			@ION (A)	UL	TÜV	VDE	BSI	IEC
TLP4006G		8-pin DIP Low trigger current General-purpose 1-Form-A/1-Form-B	—	3	25	1-Form-A 5 1-Form-B 0	0.12 [AC]	350	2500	○				
TLP4007G		8-pin DIP Low trigger current General-purpose 1-Form-A/1-Form-B	—	3	50	1-Form-A 5 1-Form-B 0	0.1 [AC]	350		○				
TLP4026G		8-pin SOP Lead pitch: 2.54 mm Low trigger current General-purpose 1-Form-A/1-Form-B	—	3	25	1-Form-A 5 1-Form-B 0	0.12 [AC]	350	1500	○				
TLP4027G		8-pin SOP Lead pitch: 2.54 mm Low trigger current General-purpose 1-Form-A/1-Form-B	—	3	50	1-Form-A 5 1-Form-B 0	0.09 [AC]	350		○				
TLP4172G		4-pin SOP Lead pitch: 2.54 mm Low trigger current General-purpose 1-Form-B	—	3	50	0	0.09 [AC]	350	○					
TLP4176G		4-pin SOP Lead pitch: 2.54 mm Low trigger current General-purpose 1-Form-B	—	3	25	0	0.12 [AC]	350	○					
TLP4192G		6-pin SOP Lead pitch: 2.54 mm Low trigger current General-purpose 1-Form-B	—	3	50	0	0.09 [AC]	350	○					
TLP4197G		6-pin SOP Lead pitch: 2.54 mm Low trigger current General-purpose 1-Form-B	—	3	25	0	0.12 [AC]	350	○					
TLP4202G		8-pin SOP Lead pitch: 2.54 mm Dual channel version of the TLP4172G 2-Form-B	—	3	50	0	0.09 [DC]	350	○					
TLP4206G		8-pin SOP Lead pitch: 2.54 mm Dual channel version of the TLP4176G 2-Form-B	—	3	25	0	0.12 [DC]	350	○					
TLP4222G		4-pin DIP Low trigger current General-purpose 1-Form-B	—	3	50	0	0.1 [AC]	350	2500	○				

Note (2): Legend in the Safety Standards column:

○: Approved ◇: SELV-approved △: Design which meets safety standard (as of 06/05)

4.9 Photorelays (MOSFET Output, 1-Form-B) (continued)

Part Number	Pin Configuration	Features	IFT		RON		V _{OFF} (V)	BV _s 1 Minute (Vrms)	Safety Standards (2)					
			Rank	Max (mA)	Max (Ω)	@I _F (mA)			@I _{ON} (A)	UL	TÜV	VDE	BSI	IEC
TLP4222G-2		Dual channel version of the TLP4222G 2-Form-B	—	3	50	0	0.1 [AC]	350	2500	○				
TLP4227G		4-pin DIP Low trigger current General-purpose 1-Form-B SEMKO-approved	—	3	25	0	0.15 [AC]	350		○				△ 60950
TLP4227G-2		Dual channel version of the TLP4227G SEMKO-approved 2-Form-B	—	3	25	0	0.15 [AC]	350		○				△ 60950
TLP4592G		6-pin DIP Low trigger current General-purpose 1-Form-B	—	3	50	0	0.1 [AC]	350		○				
TLP4597G		6-pin DIP Low trigger current General-purpose 1-Form-B SEMKO-approved	—	3	25	0	0.15 [AC]	350		○				△ 60950

Note (2): Legend in the Safety Standards column:

○: Approved ◇: SELV-approved △: Design which meets safety standard (as of 06/05)

4 Selection Guide

4.10 Products Manufactured by Toshiba Semiconductor Thailand Co., Ltd.

Part Number	Pin Configuration	Features	V _{CEO} (V)	BV _s 1 Minute (Vrms)	Safety Standards ⁽²⁾				
					UL	TÜV	VDE	BSI	IEC
TLP180(T)		Mini-flat 6-pin MFSOP AC input SEMKO-approved	80	3750	○	○ ⁽¹⁾	△		
TLP181(T)		Mini-flat 6-pin MFSOP Transistor output General-purpose	80	3750	○	△	○ ⁽¹⁾	◇ EN 60950	△ 60950
TLP521-1(T)		4-pin DIP Transistor output General-purpose	55	2500	○				
TLP521-2(T)		Dual channel version of the TLP521-1(T)			○				
TLP620(T)		4-pin DIP Transistor output AC input SEMKO-approved	55	5000	○	△ EN 60747	◇ EN 60747	◇ EN 60065 EN 60950	△ 60065 60950
TLP620-2(T)		Dual channel version of the TLP620(T) SEMKO-approved			○	△ EN 60747	◇ EN 60747	◇ EN 60065 EN 60950	
TLP621(T)		4-pin DIP Transistor output High isolation voltage SEMKO-approved	55	5000	○	△ EN 60747	◇ EN 60747	◇ EN 60065 EN 60950	△ 60065 60950
TLP621-2(T)		Dual channel version of the TLP621(T) SEMKO-approved			○	△ EN 60747	◇ EN 60747	◇ EN 60065 EN 60950	
TLP627(T)		4-pin DIP Darlington transistor output High V _{CEO} SEMKO-approved	300	5000	○	△ EN 60747	◇ EN 60747	◇ EN 60065 EN 60950	△ 60065 60950
TLP627-2(T)		Dual channel version of the TLP627(T) SEMKO-approved			○	△ EN 60747	◇ EN 60747	◇ EN 60065 EN 60950	

Note (1): The EN60747-5-2 safety standard for compact packages is different from that for standard DIP packages.

Since the mini-flat package is a compact package, please contact your nearest Toshiba sales representative for more details.

Note (2): Legend in the Safety Standards column:

○: Approved ◇: SELV-approved △: Design which meets safety standard (as of 06/05)

TÜV and VDE: EN60747-5-2-approved with option V4.

5 Package Information

6.1 Package Dimensions

Unit: mm

DIP4

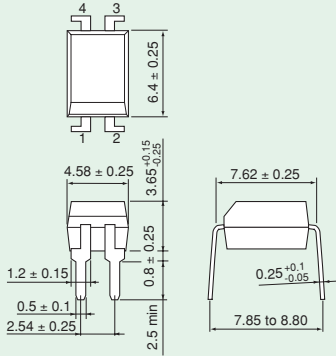

DIP4 (LF1)

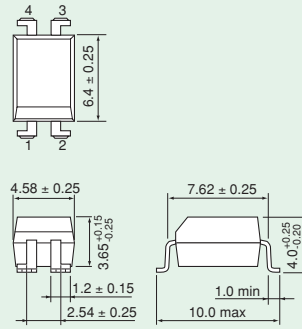

DIP4 (LF2)

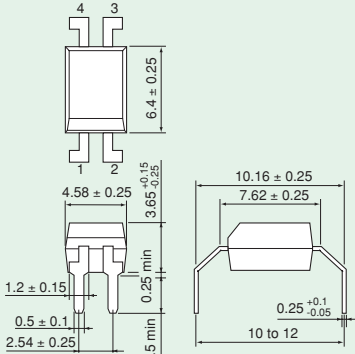

DIP4 (LF4)

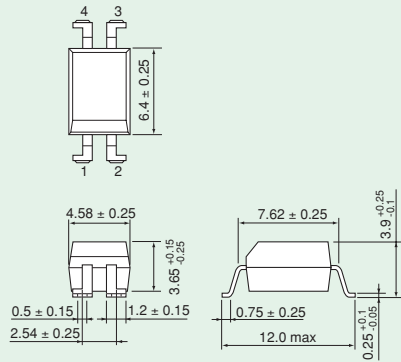

DIP4 (LF5)

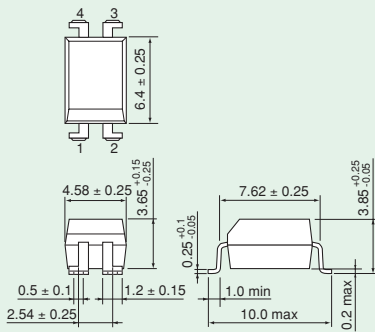

DIP6

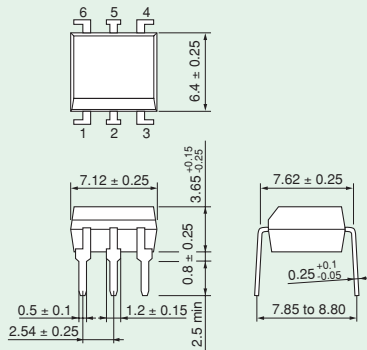

5 Package Information

5.1 Package Dimensions (continued)

Unit: mm

DIP6 (LF1)

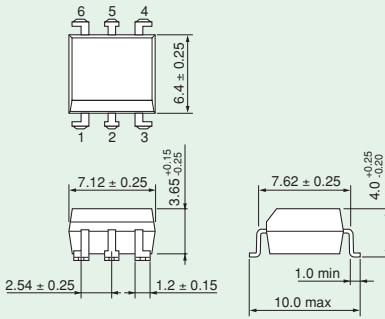

DIP6 (LF2)

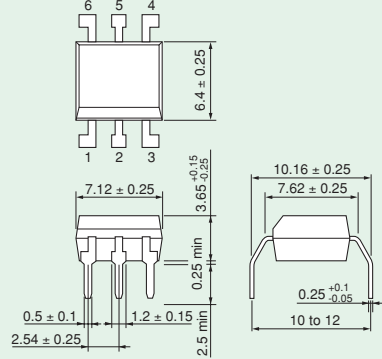

DIP6 (LF4)

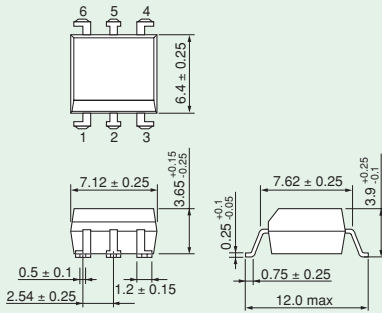

DIP6 (LF5)

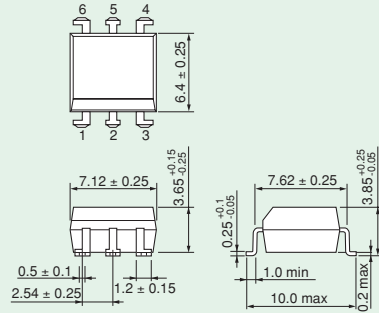

5-pin DIP6

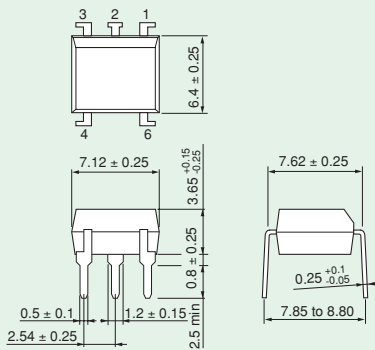

5-pin DIP6 (LF2)

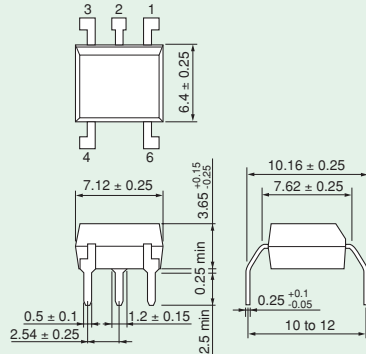

6.1 Package Dimensions (continued)

Unit: mm

5-pin DIP (Cut)

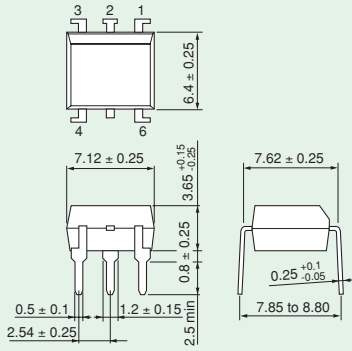

DIP8

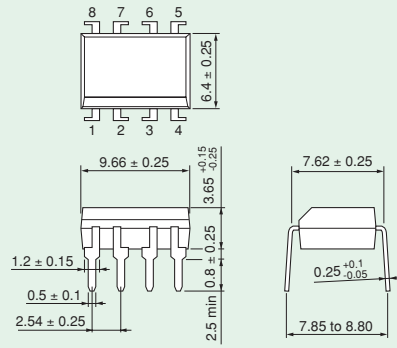

DIP8 (LF1)

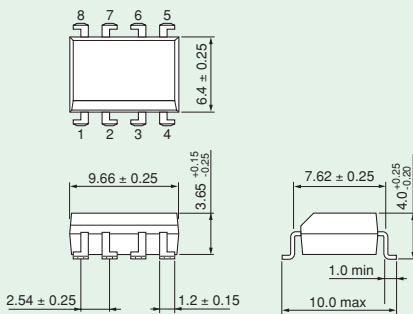

DIP8 (LF2)

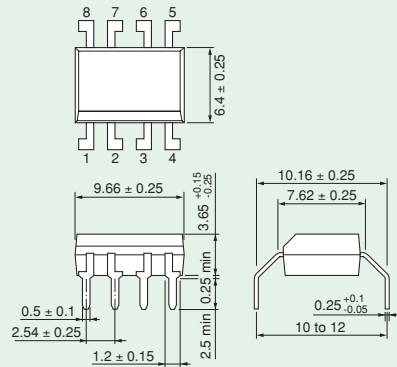

DIP8 (LF4)

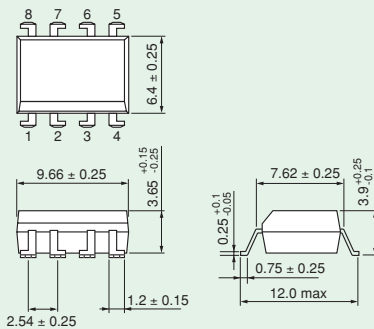

DIP16

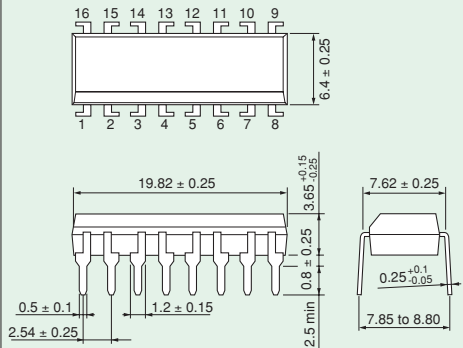

5 Package Information

6.1 Package Dimensions (continued)

Unit: mm

TLP3502, TLP3502A, TLP3503, TLP3506, TLP3507

TLP3520, TLP3520A, TLP3521, TLP3526, TLP3527

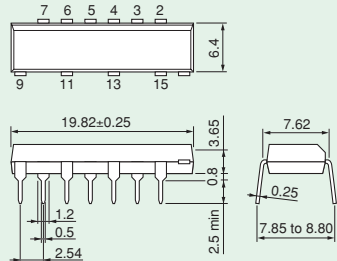
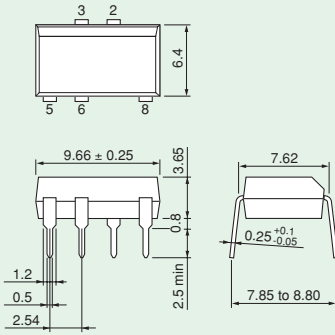

SDIP6

SDIP6 (F type)

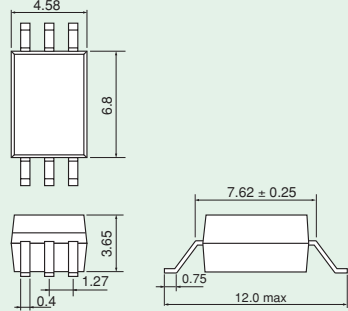
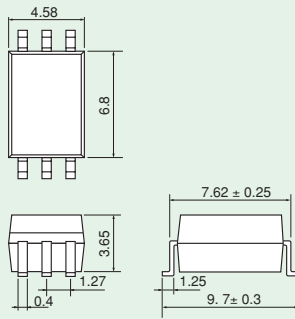

4-pin MFSOP6

5-pin MFSOP6

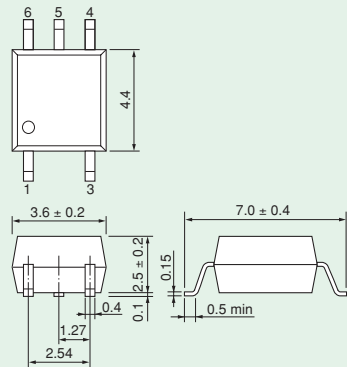
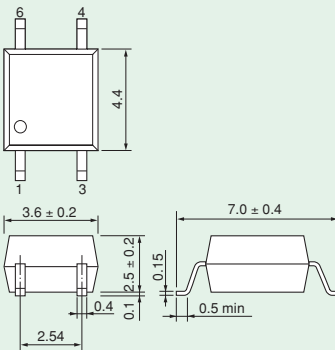

6.1 Package Dimensions (continued)

Unit: mm

4-pin MFSOP6 (No.5Cut)

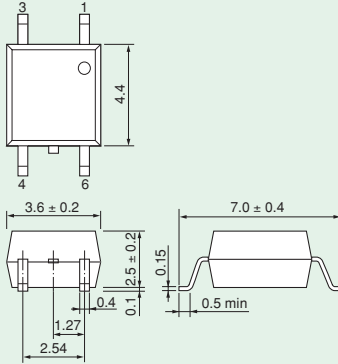

2.54SOP4

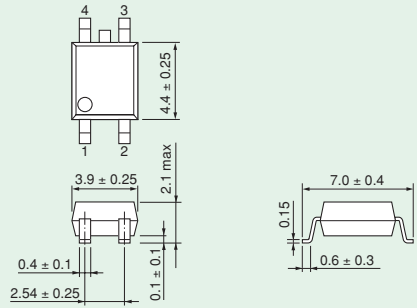

2.54SOP6

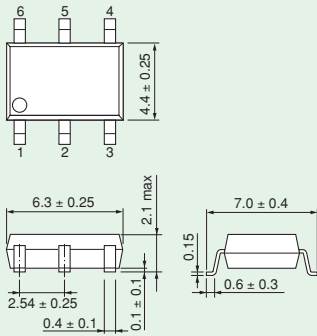

2.54SOP8

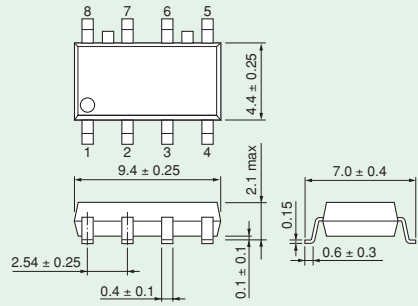

SOP4

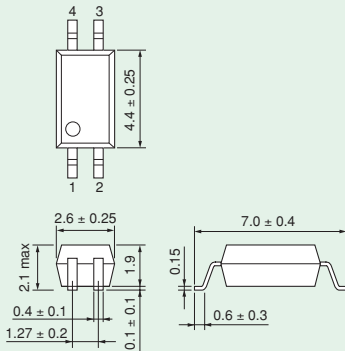

SOP16

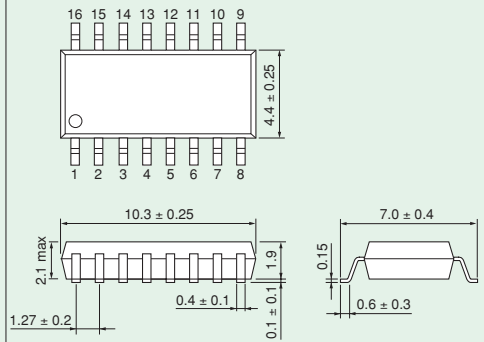

5 Package Information

5.1 Package Dimensions (continued)

Unit: mm

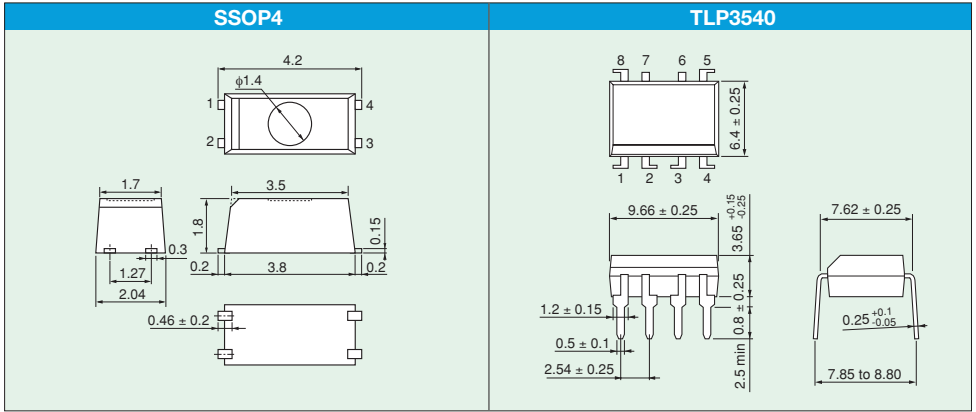

5.2 Optional Lead Formed Products

1. Surface-Mount Lead Form Options (LF1), (LF4), (LF5)

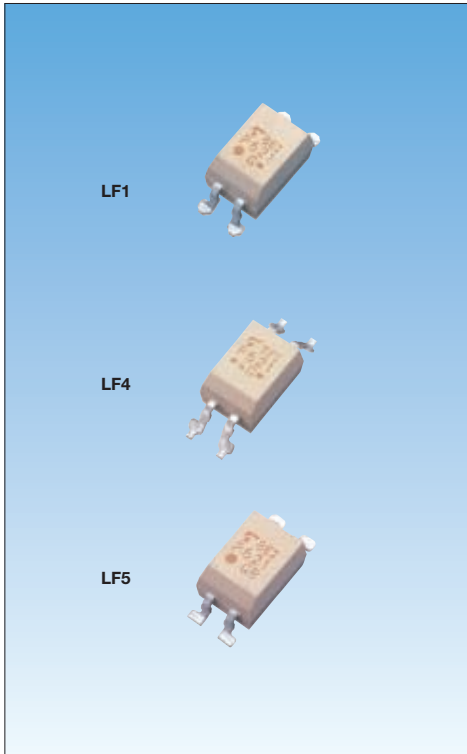

■ Package Outline

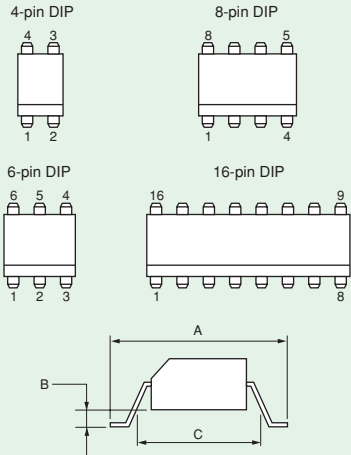

■ Dimensions

Unit: mm

Dimension \ Version	(LF1)		(LF4)		(LF5)	
	Min	Max	Min	Max	Min	Max
A	—	10.0	—	12.0	—	10.0
B	(0.35 typ.)		(0.25 typ.)		—	0.2
C	6.4	—	8.0	—	6.4	—

All other package dimensions are the same as for each standard package specifications.

■ Features

Surface-mountable: Leads of the photocouplers with (LF1), (LF4) or (LF5) part number suffix are available for all DIP packages except SDIP packages. These devices are suitable for hybrid circuits.

Applications: HIC modules, telephone exchanges, solid state relays, switching power supplies, inverter base amplifiers
This lead form option is available for all 4-, 6-, 8-, 12-, 16-pin DIP packages.

■ Ordering information

To order any standard photocoupler with a surface-mount lead form, add (LF1), (LF4) or (LF5) to the standard part number, depending on the lead form desired. When tape and reel packaging is desired, add (TP1), (TP4) or (TP5). Refer to 5.4 Tape and Reel Specifications for more details.

Example: Standard part number: TLP731 (GR)

Surface-mount type part number: TLP731 (GR-LF1), TLP731 (GR-LF4) or TLP731 (GR-LF5)

■ Safety Standard Approval

Use Toshiba standard part number for safety standards approved application.

Example

Part number	→	Approved part number
TLP731 (GR-LF1)		TLP731

Note: For more details about package dimensions, please refer to 5.1 Package Dimensions.

6.2 Optional Lead Formed Products (continued)

2. Wide-Spaced Lead Form Option (LF2)

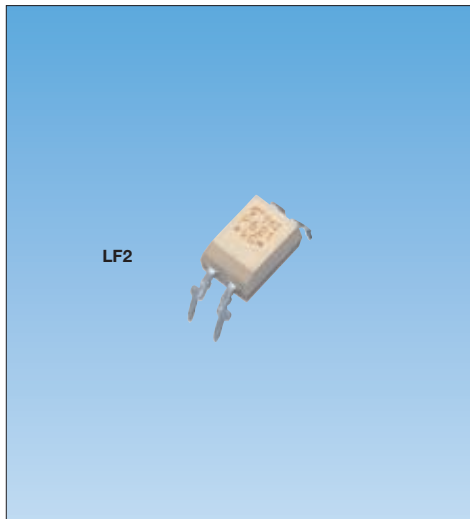

■ Package Dimensions

Unit: mm

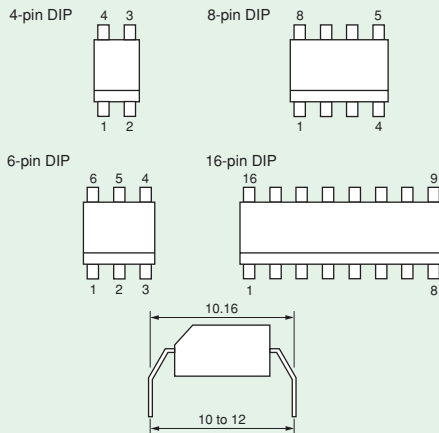

All other package dimensions are the same as for each standard package specifications.

■ Features

Wide-spaced surface-mountable: Leads of the DIP packaged photocouplers with (LF2) part number suffix are bend to satisfy 8-mm PC board spacing requirements.

Applications: Office equipment, home appliances, solid state relays, switching power supplies. The lead form option is available for all 4-, 6-, 8-, 12-, 16-pin DIP packages with electrical characteristics remain unchanged.

■ Ordering information

To order any standard photocoupler with wide-spaced lead form, add (LF2) to the standard part number.

Example: Standard part number: TLP731 (GR)

Wide-spaced part number: TLP731 (GR-LF2)

■ Safety Standard Approval

Use Toshiba standard part number for safety standards approved application.

Example

Part number		Approved part number
TLP731 (GR-LF2)	→	TLP731

Note: For more details about package dimensions, please refer to 5.1 Package Dimensions.

5.3 Photocoupler Magazine Packing Specification

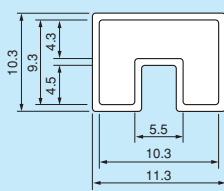
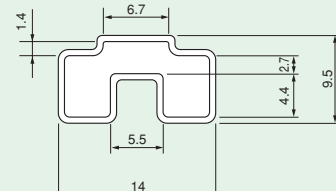
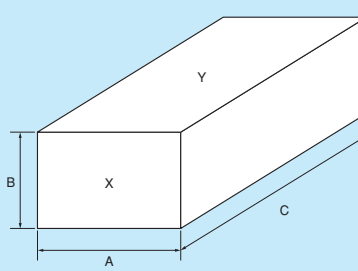
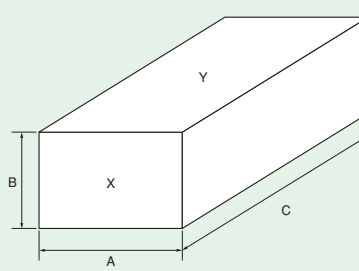
	Standard DIP	DIP LF1, LF2, LF4 and LF5 Lead Forming																					
Dimensions of Magazine	<p>Unit: mm</p>  <p>Length = 525 Thickness = 0.5</p>	<p>Unit: mm</p>  <p>Length = 525 Thickness = 0.5</p>																					
Quantities of Devices per Magazine	<table border="1"> <thead> <tr> <th>Number of Pins</th> <th>4</th> <th>6</th> <th>8</th> <th>12</th> <th>16</th> </tr> </thead> <tbody> <tr> <td>Quantity (pcs)</td> <td>100</td> <td>50</td> <td>50</td> <td>25</td> <td>25</td> </tr> </tbody> </table>						Number of Pins	4	6	8	12	16	Quantity (pcs)	100	50	50	25	25					
Number of Pins	4	6	8	12	16																		
Quantity (pcs)	100	50	50	25	25																		
Packing Dimensions	<p>Unit: mm</p>  <table border="1"> <thead> <tr> <th>Quantity of Magazines</th> <th>Dimensions (A x B x C)</th> <th>Label Position</th> </tr> </thead> <tbody> <tr> <td>4</td> <td>50 x 12 x 531</td> <td>Y</td> </tr> <tr> <td>20</td> <td>67 x 51 x 559</td> <td>Y</td> </tr> <tr> <td>60</td> <td>123 x 76 x 568</td> <td>X</td> </tr> </tbody> </table>	Quantity of Magazines	Dimensions (A x B x C)	Label Position	4	50 x 12 x 531	Y	20	67 x 51 x 559	Y	60	123 x 76 x 568	X	<p>Unit: mm</p>  <table border="1"> <thead> <tr> <th>Quantity of Magazines</th> <th>Dimensions (A x B x C)</th> <th>Label Position</th> </tr> </thead> <tbody> <tr> <td>4</td> <td>60 x 13 x 531</td> <td>Y</td> </tr> <tr> <td>40</td> <td>135 x 58 x 568</td> <td>X</td> </tr> </tbody> </table>	Quantity of Magazines	Dimensions (A x B x C)	Label Position	4	60 x 13 x 531	Y	40	135 x 58 x 568	X
Quantity of Magazines	Dimensions (A x B x C)	Label Position																					
4	50 x 12 x 531	Y																					
20	67 x 51 x 559	Y																					
60	123 x 76 x 568	X																					
Quantity of Magazines	Dimensions (A x B x C)	Label Position																					
4	60 x 13 x 531	Y																					
40	135 x 58 x 568	X																					

5 Package Information

5.3 Photocoupler Magazine Packing Specification (continued)

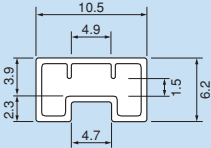
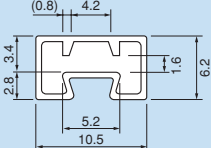
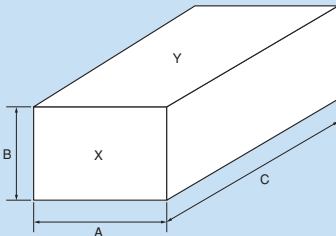
	Mini-Flat Coupler (MFP)	SOP Photocoupler																				
Dimensions of Magazine	<p>Unit: mm</p>  <p>Length = 555 Thickness = 0.5</p>	<p>Unit: mm</p>  <p>Length = 555 Thickness = 0.5</p>																				
Quantities of Devices per Magazine	<table border="1"> <thead> <tr> <th>Number of Pins</th> <th>4 (MFSOP4)</th> </tr> </thead> <tbody> <tr> <td>Quantity (pcs)</td> <td>150</td> </tr> </tbody> </table>	Number of Pins	4 (MFSOP4)	Quantity (pcs)	150	<table border="1"> <thead> <tr> <th>Number of Pins</th> <th>4 (SOP4)</th> <th>16 (SOP16)</th> <th></th> </tr> </thead> <tbody> <tr> <td>Quantity (pcs)</td> <td>150</td> <td>50</td> <td></td> </tr> </tbody> </table> <table border="1"> <thead> <tr> <th>Number of Pins</th> <th>4 (2.54SOP4)</th> <th>6 (2.54SOP6)</th> <th>8 (2.54SOP8)</th> </tr> </thead> <tbody> <tr> <td>Quantity (pcs)</td> <td>100</td> <td>75</td> <td>50</td> </tr> </tbody> </table>	Number of Pins	4 (SOP4)	16 (SOP16)		Quantity (pcs)	150	50		Number of Pins	4 (2.54SOP4)	6 (2.54SOP6)	8 (2.54SOP8)	Quantity (pcs)	100	75	50
Number of Pins	4 (MFSOP4)																					
Quantity (pcs)	150																					
Number of Pins	4 (SOP4)	16 (SOP16)																				
Quantity (pcs)	150	50																				
Number of Pins	4 (2.54SOP4)	6 (2.54SOP6)	8 (2.54SOP8)																			
Quantity (pcs)	100	75	50																			
Packing Dimensions		<p>Unit: mm</p> <table border="1"> <thead> <tr> <th>Quantity of Magazines</th> <th>Dimensions (A x B x C)</th> <th>Label Position</th> </tr> </thead> <tbody> <tr> <td>4</td> <td>29 x 13 x 563</td> <td>Y</td> </tr> <tr> <td>24</td> <td>77 x 31 x 586</td> <td>Y</td> </tr> <tr> <td>60</td> <td>67 x 55 x 586</td> <td>X</td> </tr> </tbody> </table>	Quantity of Magazines	Dimensions (A x B x C)	Label Position	4	29 x 13 x 563	Y	24	77 x 31 x 586	Y	60	67 x 55 x 586	X								
Quantity of Magazines	Dimensions (A x B x C)	Label Position																				
4	29 x 13 x 563	Y																				
24	77 x 31 x 586	Y																				
60	67 x 55 x 586	X																				

Photocoupler Package Type		Typical Devices
MFC	A	TLP114A, TLP160J, TLP180, TLP190B
	B	TLP280, TLP281
SOP	C	TLP280-4, TLP281-4, TLP270D, TLP270G
	D	TLP176G, TLP176A
	E	TLP197G
	F	TLP206G, TLP206A

A: MFSOP6
B: SOP4
C: SOP16
D: 2.54SOP4
E: 2.54SOP6
F: 2.54SOP8

5.4 Tape and Reel Specifications

1. Embossed Tape Packaging Specifications for Surface-Mount Lead Form Options

Photocoupler Package Types	Tape Option Symbol	Typical Devices
MFSOP6	(TPL) or (TPR)	TLP114A, TLP165J, TLP181, TLP190B
SOP4	(TP)	TLP280, TLP281
SOP16	(TP)	TLP280-4, TLP281-4, TLP270D, TLP270G
2.54SOP4	(TP)	TLP176G, TLP176A, TLP176D
2.54SOP6	(TP)	TLP197G
2.54SOP8	(TP)	TLP200D, TLP206A, TLP206G
SSOP4	(TP15)	TLP3213 to 3217, TLP3230, TLP3231
DIP(LF1, LF5)	(TP1) or (TP5)	TLP550, TLP560G, TLP421
DIP(LF4)	(TP4)	TLP251, TLP560G, TLP421
SDIP	(TP)	TLP701

2. Tape Dimensions

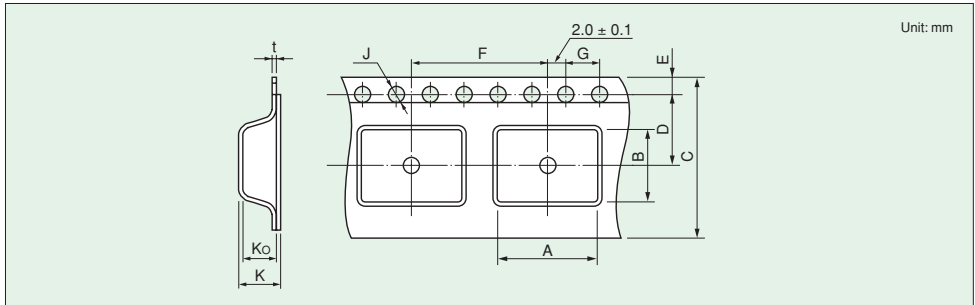

Unit: mm

Photocoupler Package Type	MFSOP6	SOP4	SOP16	2.54SOP4	2.54SOP6	2.54SOP8	SSOP4	DIP(LF1,LF5)	DIP(LF4)	SDIP	
Tape Option	(TPL), (TPR)	(TP)	(TP)	(TP)	(TP)	(TP)	(TP15)	(TP1),(TP5)	(TP4)	(TP)	
Symbol (See Figure above)	A	4.2 ± 0.1	3.1 ± 0.1	7.5 ± 0.1	4.3 ± 0.1	7.5 ± 0.1	2.35 ± 0.2	10.4 ± 0.1	12.3 ± 0.1	10.4	
	B	7.6 ± 0.1	7.5 ± 0.1	10.5 ± 0.1	7.5 ± 0.1	6.7 ± 0.1	10.5 ± 0.1	4.5 ± 0.1	*1	*1	5.1
	C	12.0 ± 0.3	12.0 ± 0.3	16.0 ± 0.3	12.0 ± 0.3	16.0 ± 0.3	16.0 ± 0.3	12.0 ± 0.3	16.0 ± 0.3		16.0
	D	5.5 ± 0.1	7.5 ± 0.1	5.5 ± 0.1	5.5 ± 0.1	7.5 ± 0.1	5.5 ± 0.1	5.5 ± 0.1	7.5 ± 0.1		7.5
	E	1.75 ± 0.1									1.75
	F	8.0 ± 0.1	12.0 ± 0.1	8.0 ± 0.1	12.0 ± 0.1	4.0 ± 0.1	12.0 ± 0.1	16.0 ± 0.1			12.0
	G	4.0 ± 0.1									4.0
	J	1.5 ^{+0.1} ₋₀									1.5
	K	3.15 ± 0.2	2.5 ± 0.2	2.4 ± 0.2	2.6 ± 0.2	2.5 ± 0.2	2.4 ± 0.2	2.4 ± 0.2	4.55 ± 0.2		4.55
	Ko	2.8 ± 0.1	2.3 ± 0.1	2.2 ± 0.1	2.4 ± 0.1	2.3 ± 0.1	2.2 ± 0.1	2.1 ± 0.1	4.1 ± 0.1		4.1
	t	0.3 ± 0.05							0.4 ± 0.05		

*1: Typical devices

DIP4	TLP620, TLP421, TLP721	5.1 ± 0.1
DIP6 (short package)	TLP631, TLP734, TLP747G	7.6 ± 0.1
DIP6 (long package)	TLP595G, TLP666G, TLP3020	10.1 ± 0.1 (TP4) is not available.
DIP8	TLP250, TLP555, TLP2601	

5 Package Information

5.4 Tape and Reel Specifications (continued)

3. Reel Dimensions

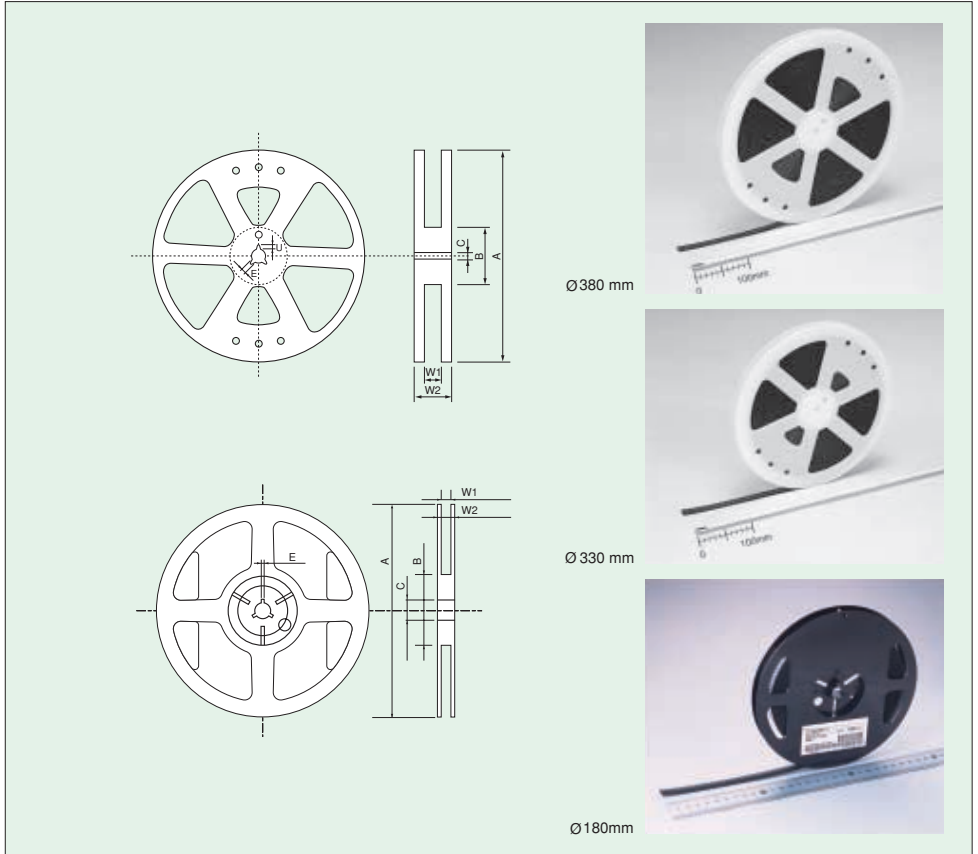

Unit: mm

Photocoupler Package Type		MFSOP	SOP4	SOP16	2.54SOP4	2.54SOP6	2.54SOP8	SSOP4	DIP(LF1, LF5)	DIP(LF4)	SDIP6
Tape Option		(TPL), (TPR)	(TP)	(TP)	(TP)			(TP15)	(TP1), (TP5)	(TP4)	(TP)
Symbol (See Figure above)	A	Dimensions	Ø 380 ± 2		Ø 330 ± 2			180 ⁺⁰ ₋₄	Ø 380 ± 2		
	B		Ø 80 ± 1			Ø 60			Ø 80 ± 1		
	C		Ø 13 ± 0.5			Ø 13			Ø 13 ± 0.5		
	E		2.0 ± 0.5			2 ± 0.5			2.0 ± 0.5		
	U		4.0 ± 0.5			4.0 ± 0.5			4.0 ± 0.5		
	W1		13.5 ± 0.5	17.5 ± 0.5	13.5 ± 0.5	17.5 ± 0.5		13 ± 0.3	17.5 ± 0.5		
	W2		17.5 ± 1.0	21.5 ± 1.0	17.5 ± 1.0	21.5 ± 1.0		15.4 ± 1.0	21.5 ± 1.0		

5.4 Tape and Reel Specifications (continued)

4. Other Packing Information

(a) Device orientation on tape

The orientations of photocouplers in cavity are shown below.

A)	Photocoupler Package Type	Tape Option
	MFSOP6	TPR
B)	Photocoupler Package Type	Tape Option
	MFSOP6	TPL
	SOP4, 2.54SOP4	TP
	SSOP4	TP15
C)	Photocoupler Package Type	Tape Option
	SOP16	TP
	2.54SOP6/8	TP
	DIP (LF1, LF5)	TP1, TP5
	DIP (LF4)	TP4
D)	Photocoupler Package Type	Tape Option
	SDIP6	TP

User direction of feed →

(b) Taping Specifications

● Quantities per Reel

Photocoupler Package Type	MFSOP6	SOP4	SOP16	2.54SOP4/6/8	SSOP4	DIP (LF1, LF5)	DIP (LF4)	SDIP6 (TP)
Quantities (pcs)	3000	2500	2500	2500	1500	1500	1000	1500

● Empty Cavities :

Item	Specification	Note
Consecutive empty cavities	Zero	Any 40 mm portion of tape except leader and trailer.
Nonconsecutive empty cavities	0.2% max/reel *#2	Except leader and trailer.

*#2: 6 pcs max/reel for DIP types

(c) Packing boxes

2 types: One-reel box or five-reel box.

(d) Label

The reel label includes the following information.

1. Part number 2. Tape type 3. Quantity 4. Lot number

(e) Purchase order

Specify the part number, tape and quantity as follows.

Example TLP181 (GB - TPR) 3000 pcs

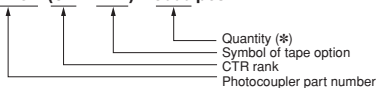

*Per reel must be a multiple of quantity

6.5 PC Board Mounting for Mini-Flat Coupler, SOP Coupler and Lead Formed Coupler

1. Recommended Footprint Dimensions

Below are the recommended footprint (mount pad) dimensions for surface-mount packages.

Mini-flat coupler and SOP coupler

(Unit: mm)

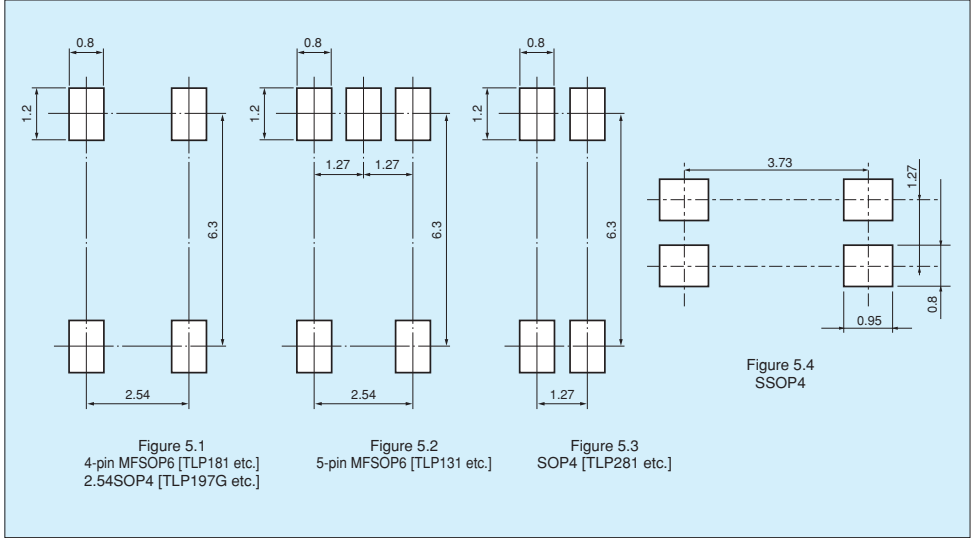

Surface-Mount Lead-Formed Coupler (Example: 6-pin DIP package)

(Unit: mm)

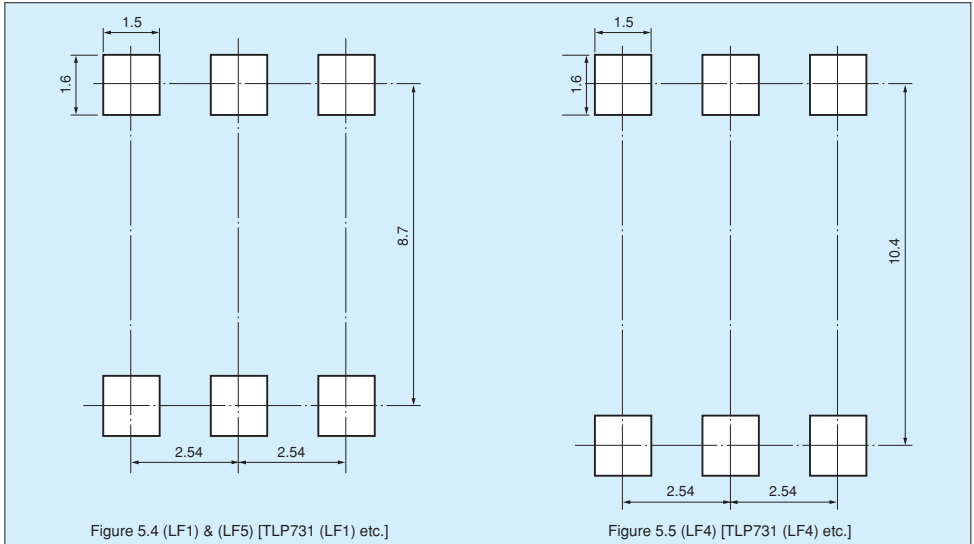

6.5 PC Board Mounting for Mini-Flat Coupler, SOP Coupler and Lead Formed Coupler

2. Soldering

When using a soldering iron or medium infrared ray/hot air reflow, avoid rise in device temperature as much as possible by observing the following conditions.

2.1) Using a soldering iron

Complete soldering within ten seconds for lead temperature of up to 260°C.

2.2) Using medium infrared ray/hot air reflow

- Complete the infrared ray/hot air reflow process within 30 seconds at a package surface temperature of between 210°C and 240°C.
- Refer to the figure below for an example of a good temperature profile for medium infrared ray/hot air reflow.

Pb

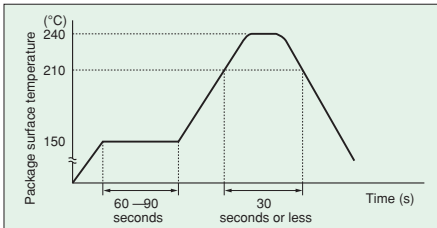

Pb-free

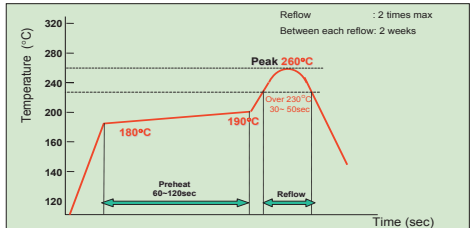

c. Precautions for heating

If packages have been kept at high temperature for a long period of time, it can degrade the quality and reliability of devices. Soldering time has to be kept as short as possible to avoid rise in package temperature.

When using a halogen lamp or infrared heater, avoid direct irradiation to packages, as this may cause rise in package temperature.

2.3) Dip soldering (Flow soldering)

The thermal shock of the dip soldering is intended to increase thermal stress to devices. To avoid the stress, a soldering iron or medium infrared ray/hot air reflow is recommended. When dip soldering is considered, please contact your nearest Toshiba sales office.

3. Flux Cleaning

- When cleaning circuit boards to remove flux, make sure that no residual reactive ions such as Na or Cl remain. Note that organic solvents react with water to generate hydrogen chloride and other corrosive gases which can degrade device performance.
- Washing devices with water will not cause any problems. However, make sure that no reactive ions such as sodium and chlorine are left as residue. Also, be sure to dry devices sufficiently after washing.
- Do not rub device markings with a brush or with your hand during cleaning or while the devices are still wet from the cleaning agent. Doing so can rub off the markings.
- The dip cleaning, shower cleaning and steam cleaning processes all involve the chemical action of a solvent. Use only recommended solvents for these cleaning methods. When immersing devices in a solvent or steam bath, make sure that the temperature of the liquid is 50°C or below, and that the circuit board is removed from the bath within one minute.
- If a device package allows ultrasonic cleaning, limit the duration of ultrasonic cleaning to as short as possible, since long hours of ultrasonic cleaning degrade the adhesion between the mold resin and the frame material.

The following ultrasonic cleaning conditions are recommended.

Frequency: 27 kHz to 29 kHz
 Ultrasonic output power: 300 W or less (0.25 W/cm² or less)
 Cleaning time: 30 seconds or less

Suspend the circuit board in the solvent bath during ultrasonic cleaning in such a way that the ultrasonic vibrator does not come into direct contact with the circuit board or the device.

Conventional cleaning solvents that contain Freon are not recommended due to the danger that they pose to the earth's ozone layer. Alternative products are available on the market. Some alternative cleaning agents that do not contain Freon listed in Table below.

Contact Toshiba or a Toshiba distributor regarding cleaning conditions and other relevant information for each product type.

Example of Alternative Cleaning Agents

Technocare	FRW-1, FRW-17, FRV-100	from Toshiba Corporation
Asahi Clean	AK-225AES	from Asahi Glass Co., Ltd
Clean Through	750H	from Kao Co., Ltd.

6 Supplementary Information

6.1 Current Transfer Ratio (CTR), LED Trigger Current (I_{FT}) Ranking and Marking

Standard rank classifications are applied for the CTR of transistor output devices and for the I_{FT} of MOSFET, SCR, Triac output devices. Indicative product markings corresponding to rank names are as shown below.

Also, note that the applied rank classifications depend on product types. For details, refer to relevant technical datasheets.

1. CTR Rank Name and Rank Marking

Available CTR Rank Selection (○: Available, △: Call Toshiba)

Part Number	Rank Name										Rank Marking Group
	None	GB	Y	GR	BL	YH	GRL	GRH	BLL		
TLP180	○	○	△	○	△						①
TLP181	○	○	○	○	○	○	○	○	○	○	②
TLP280	○	○	△	○	△						①
TLP280-4	○	○									③
TLP281	○	○	○	○	○	○	○	○	○	○	②
TLP281-4	○	○									③
TLP321	○	○	○	○	○						②
TLP321-2	○	○		○	△						①
TLP321-4	○	○									③
TLP421/421F	○	○	○	○	○	○	○	○	○	○	TLP421
TLP521-1	○	○	○	○	○	○	○	○	○	○	②
TLP521-2	○	○	△	○	△						①
TLP521-4	○	○									③
TLP531/532	○	○	△	○	△						①
TLP620	○	○	△	○	△						①
TLP620-2	○	○									③
TLP620-4	○	○									③
TLP621	○	○	○	○	○	○	○	○	○	○	②
TLP621-2	○	○	△	○	△						①
TLP621-4	○	○									③
TLP630	○	○	△	○	△						①
TLP631/632	○	○	△	○	△						②
TLP721	○	○	△	○	△	○	○	○	○	○	②
TLP731/732	○	○	△	○	△						②
TLP733F/734F	○	○	△	○	△						②

*Blank list by part number

Rank Name	CTR	CTR	
		Other than TLP421	TLP421
None	50 to 600%	*Refer to Blank list by part number.	Blank, Y, Y+, YE, G, G+, GR, B, B+, BL, GB
Y	50 to 150%	YE	YE
GR	100 to 300%	GR	GR
GB	100 to 600%	GB	GB
BL	200 to 600%	BL	BL
YH	75 to 150%	Y [#]	Y+
GRL	100 to 200%	G	G
GRH	150 to 300%	G [#]	G+
BLL	200 to 400%	B	B

Part Number	Blank	Rank Marking Group	Part Number	Blank	Rank Marking Group
TLP180	Blank, YE, GR, BL, GB	①	TLP280-4	Blank, GB	③
TLP280					
TLP321-2					
TLP521-2					
TLP531/532					
TLP620					
TLP621-2					
TLP630					
TLP181					
TLP281					
TLP321	Blank, Y, Y [#] , YE, G, G [#] , GR, B, B [#] , BL, GB	②	TLP521-1		
TLP531					
TLP621					
TLP631					
TLP632					
TLP721					
TLP731					
TLP732					
TLP733F					
TLP734F					

6.1 LED Trigger Current (IFT) Ranking and Marking

2. IFT Rank Name and Rank Marking

Rank Name	IFT	IFT Rank Marking
None	IFT max	Blank, T7, T5
IFT7	7 mA max	T7, T5
IFT5	5 mA max	T5
IFT2	2 mA max	T2 (only for photorelays)

3. Marking Example

(a) 4-pin Type & Mini-Flat 1-ch Type

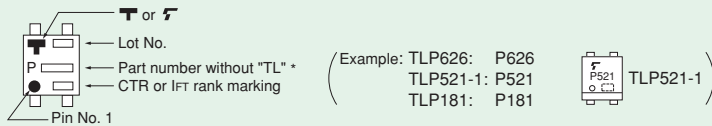

(b) TLP421, TLP421F

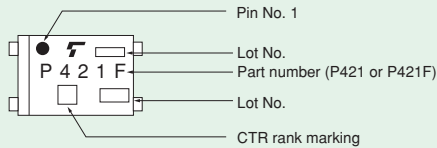

(c) TLP280, TLP281

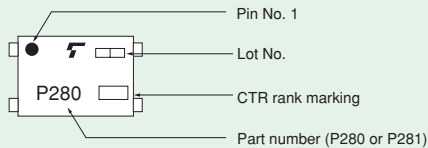

(d) Others

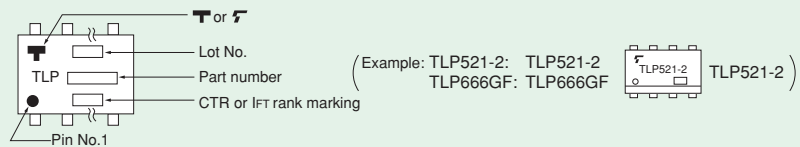

Note: To order any standard photocoupler, add rank marking in parenthesis to the standard part number.

Example: TLP521-1 (GB), TLP532 (GR)

Use Toshiba standard part number for safety standards approved application.

Example $\frac{\text{Part number}}{\text{TLP621(GR)}} \longrightarrow \frac{\text{Approved part number}}{\text{TLP621}}$

6 Supplementary Information

6.2 Projected Operating Life Based on LED Light Output Degradation

Toshiba photocouplers use one of three types of LEDs and a projection of the operating life is expected for each LED. The table on page 54 shows types of LED used in photocouplers and the figures on page 55 to 57 show projections of long-term light output performance and operating life. Note that those operating life data are estimates extrapolated from long-term light output degradation over a single wafer lot and are shown as reference only.

	Projected Operating Life ($T_a = 40^\circ\text{C}$, $I_f = 20\text{ mA}$, failure criteria: degradation rate $\Delta P_o < -50\%$)		Photocouplers
	F50% operating life	F0.1% operating life	
① GaAs LED	400,000 h	80,000 h	Mainly for phototransistor output devices and phototriac output devices
② GaAlAs(SH) LED	550,000 h	180,000 h	Mainly for photo-IC couplers
③ GaAlAs(DH) LED	330,000 h	65,000 h	Mainly for photorelays (MOSFET output), photovoltaic couplers and photo-IC couplers

F50% (cumulative failure rate 50%) operating life: Time period until projected long-term light output degradation curve of average light output change (\bar{X}) shown on pages 55 to 57 reaches the failure criteria.

F0.1% (cumulative failure rate 0.1%) operating life: Time period until projected long-term light output degradation curve of $\bar{X} - 3\sigma$ shown on pages 55 to 57 reaches the failure criteria.

The relationship between LED light output degradation and optical coupling characteristics is shown below.

(1) The relationship between LED light output degradation and current transfer ratio (CTR)/short circuit current (I_{sc}) is 1:1.

$$\frac{CTR(t)}{CTR(o)} = \frac{P_o(t)}{P_o(o)}$$

(2) The relationship between a reciprocal value of LED light output degradation and $I_{FT}/I_{FLH}/I_{FHL}/I_{FH}$ change is 1:1.

$$\frac{I_{FT}(t)}{I_{FT}(o)} = \left(\frac{P_o(t)}{P_o(o)} \right)^{-1}$$

● How to estimate an operating life from the graph

Example: Estimate an operating life from GaAs LED projected operating life data (failure criteria $\Delta P_o < -50\%$) on page 55.

At ambient temperature of 25°C

1. Calculate absolute temperature. $25^\circ\text{C} + 273 = 298\text{ (K)}$
2. Calculate the reciprocal value of the calculated value. $1/298 = 3.36 \times 10^{-3}$
3. Read data from the graph.

Projected operating life at $T_a = 25^\circ\text{C}$, $I_f = 50\text{ mA}$ (failure criteria: light output degradation $\Delta P_o < -50\%$)

F50% (cumulative failure rate 50%) operating life: Approximately 60,000 h (reference value)

F0.1% (cumulative failure rate 0.1%) operating life: Approximately 12,000 h (reference value)

6.2 Projected Operating Life Based on LED Light Output Degradation (continued)

LED used in Photocouplers

Photocouplers	LED	Photocouplers	LED	Photocouplers	LED	Photocouplers	LED	Photocouplers	LED
4N25(SHORT)	①	TLP131	①	TLP332	①	TLP571	①	TLP750 series	②
4N25A(SHORT)	①	TLP137	①	TLP350	②	TLP572	①	TLP751 series	②
4N26(SHORT)	①	TLP141G	①	TLP351 series	②	TLP590B	③	TLP759 series	②
4N27(SHORT)	①	TLP160 series	①	TLP371	①	TLP591B	③	TLP762J series	①
4N28(SHORT)	①	TLP161 series	①	TLP372	①	TLP592 series	①	TLP763J series	①
4N29(SHORT)	①	TLP165J	①	TLP373	①	TLP594 series	①	TLP797 series	①
4N29A(SHORT)	①	TLP166J	①	TLP421 series	①	TLP597 series	①	TLP798G	③
4N30(SHORT)	①	TLP168J	③	TLP504A	①	TLP598 series	③	TLP2200	②
4N31(SHORT)	①	TLP172 series	①	TLP511GA	①	TLP599 series	①	TLP2530	②
4N32(SHORT)	①	TLP174G	①	TLP512	②	TLP611J	①	TLP2531	②
4N32A(SHORT)	①	TLP176 series	①	TLP513	②	TLP620 series	①	TLP2601	②
4N33(SHORT)	①	TLP180	①	TLP521-1	①	TLP621 series	①	TLP260J	①
4N35(SHORT)	①	TLP181	①	TLP521-2	①	TLP624 series	①	TLP2630	②
4N36(SHORT)	①	TLP190B	③	TLP521-4	①	TLP626 series	①	TLP2631	②
4N37(SHORT)	①	TLP191B	③	TLP523 series	①	TLP627 series	①	TLP3022(S) series	①
4N38(SHORT)	①	TLP192 series	①	TLP525G series	①	TLP628 series	①	TLP3042(S) series	①
4N38A(SHORT)	①	TLP197 series	①	TLP531	①	TLP629 series	①	TLP3063(S) series	③
6N135	②	TLP200D	①	TLP532	①	TLP630	①	TLP31xx series	①
6N136	②	TLP202 series	①	TLP541G	①	TLP631	①	TLP3502	①
6N137	②	TLP206 series	①	TLP542G	①	TLP632	①	TLP3502A	①
6N138	②	TLP222 series	①	TLP543J	①	TLP641 series	①	TLP3503	①
6N139	②	TLP224G series	①	TLP545J	①	TLP651	②	TLP3506	①
TLP102	②	TLP225A	①	TLP550	②	TLP701	②	TLP3507	①
TLP106	②	TLP227 series	①	TLP551	②	TLP702	②	TLP3520	①
TLP112	②	TLP250 series	②	TLP552	②	TLP705	②	TLP3520A	①
TLP112A	③	TLP251 series	②	TLP553	②	TLP706	②	TLP3521	①
TLP113	②	TLP270 series	①	TLP554	②	TLP719	②	TLP3526	①
TLP114A	③	TLP280 series	①	TLP555	②	TLP722	②	TLP3527	①
TLP115	②	TLP281 series	①	TLP557	②	TLP731	①	TLP3530	①
TLP115A	③	TLP283 series	①	TLP558	②	TLP732	①	TLP3540	①
TLP124	①	TLP296G	①	TLP559	②	TLP733 series	①	TLP4xxx series	①
TLP126	①	TLP320 series	①	TLP560 series	①	TLP734 series	①	SDIP	②
TLP127	①	TLP330	①	TLP561 series	①	TLP741 series	①		
TLP130	①	TLP331	①	TLP570	①	TLP747 series	①		

6 Supplementary Information

6.2 Projected Operating Life Based on LED Light Output Degradation (continued)

GaAs LED Projected Light Output Degradation Data

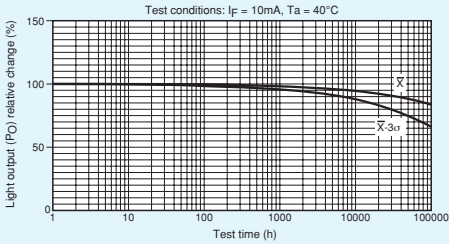
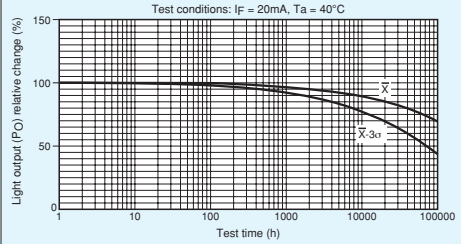
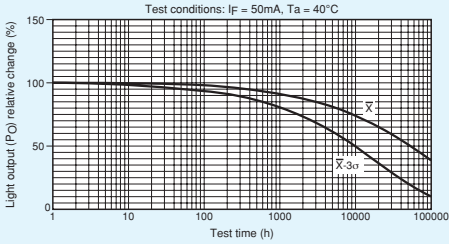

GaAs LED Projected Operating Life Data

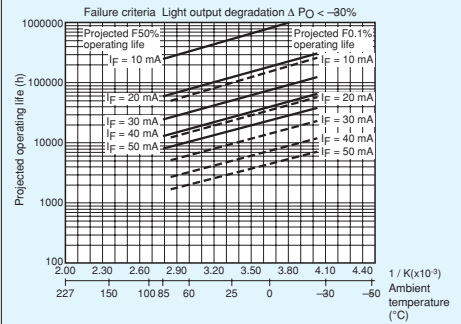
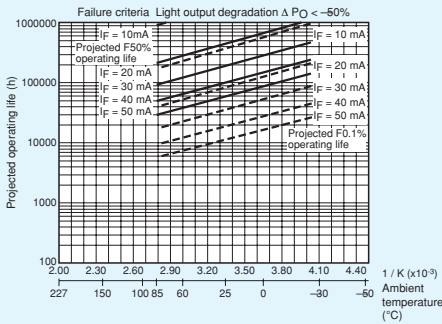

The above operating life data are estimates extrapolated from long-term light output degradation over a single wafer lot and are shown as reference only. The operating conditions exceeding the maximum ratings are not guaranteed.

6.2 Projected Operating Life Based on LED Light Output Degradation (continued)

GaAs (SH) LED Projected Light Output Degradation Data

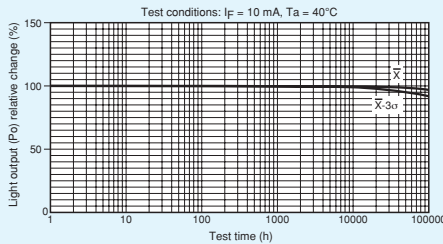
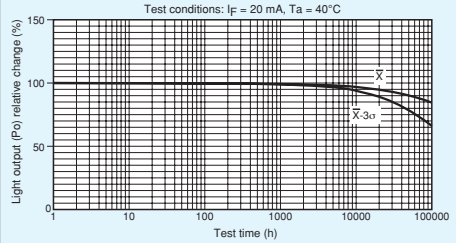
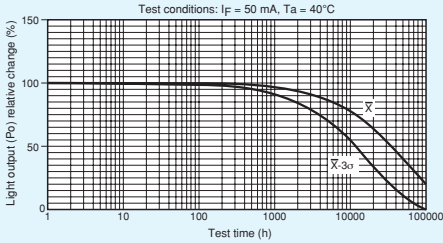

GaAs (SH) LED Projected Operating Life Data

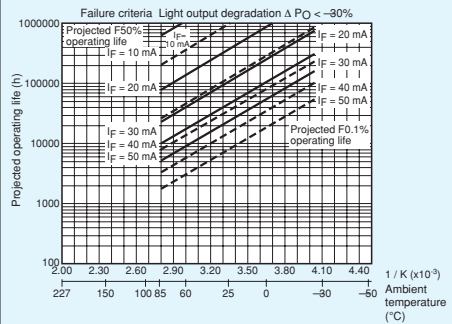
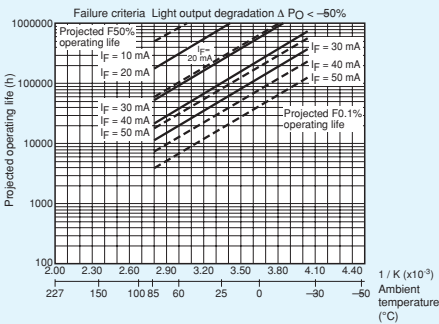

The above operating life data are estimates extrapolated from long-term light output degradation over a single wafer lot and are shown as reference only. The operating conditions exceeding the maximum ratings are not guaranteed.

6 Supplementary Information

6.2 Projected Operating Life Based on LED Light Output Degradation (continued)

GaAs LEDs (DH) LED Projected Light Output Degradation Data

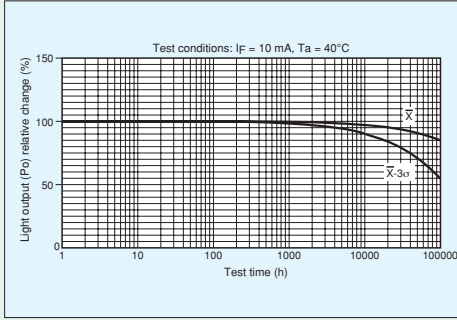
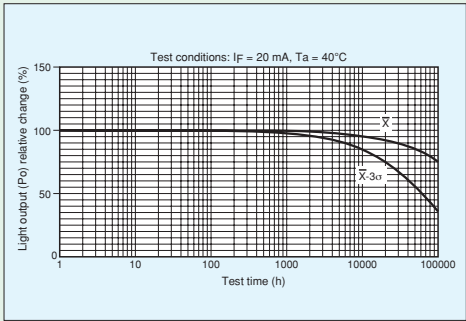
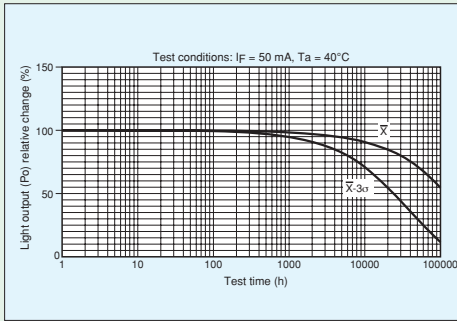

GaAs LEDs (DH) LED Projected Operating Life Data

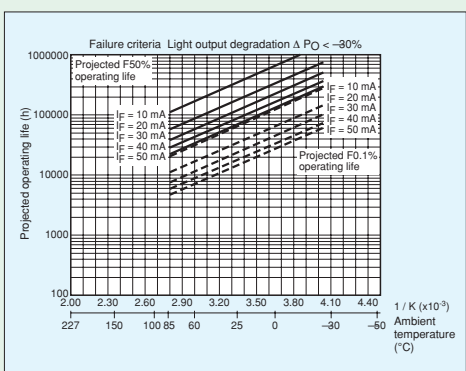
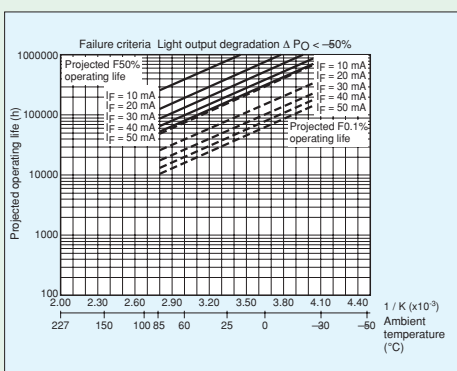

The above operating life data are estimates extrapolated from long-term light output degradation over a single wafer lot and are shown as reference only. The operating conditions exceeding the maximum ratings are not guaranteed.

7 Safety Standard Approved Photocouplers

○, △: Approved —: Not approved □: Under application

as of Sep. 04

	Product number	Construction Mechanical Ratings (min)				UL UL1577	VDE/TÜV EN60747	BSI		SEMKO EN60950	Internal Construction
		Isolation Creepage Path (mm)	Isolation Clearance (mm)	Isolation thickness (mm)	Isolation Voltage (mm)			EN60950	EN60065		
TLP 1xx	TLP102	4.0	4.0	—	3750	○	—	—	—	—	④
	TLP106	4.0	4.0	—	3750	○	—	—	—	—	
	TLP112	4.0	4.0	—	2500	○	—	—	—	—	
	TLP112A	4.0	4.0	—	2500	○	—	—	—	—	
	TLP113	4.0	4.0	—	2500	○	—	—	—	—	
	TLP114A	4.0	4.0	—	3750	○	—	—	—	—	
	TLP115	4.0	4.0	—	2500	○	—	—	—	—	
	TLP115A	4.0	4.0	—	2500	○	—	—	—	—	
	TLP124	4.0	4.0	—	3750	○	—	—	—	—	
	TLP126	4.0	4.0	—	3750	○	—	—	—	—	
	TLP127	4.0	4.0	—	2500	○	—	○	○	—	
	TLP130	4.0	4.0	—	3750	○	—	—	—	—	
	TLP131	4.0	4.0	—	3750	○	—	—	—	—	
	TLP137	4.0	4.0	—	3750	○	—	—	—	—	
	TLP141G	4.0	4.0	—	2500	○	—	—	—	—	
	TLP160G	4.0	4.0	—	2500	○	△note 2	—	—	—	
	TLP160J	4.0	4.0	—	2500	○	△note 2	—	—	—	
	TLP161G	4.0	4.0	—	2500	○	△note 2	—	—	—	
	TLP161J	4.0	4.0	—	2500	○	△note 2	—	—	—	
	TLP165J	4.0	4.0	—	2500	○	△note 2	—	—	—	
	TLP166J	4.0	4.0	—	2500	○	△note 2	—	—	—	
	TLP168J	4.0	4.0	—	2500	○	△note 2	—	—	—	
	TLP172A	4.0	4.0	—	1500	○	—	—	—	—	
	TLP172G	4.0	4.0	—	1500	○	—	—	—	—	
	TLP176A	4.0	4.0	—	1500	○	△note 2	—	—	—	
	TLP176D	4.0	4.0	—	1500	○	△note 2	—	—	—	
	TLP176G	4.0	4.0	—	1500	○	△note 2	○	○	○	
	TLP176GA	4.0	4.0	—	1500	○	—	○	○	○	
	TLP179D	4.0	4.0	—	1500	○	—	—	—	—	
	TLP180	4.0	4.0	0.4	3750	○	△note 2	○	○	○	
	TLP181	4.0	4.0	0.4	3750	○	△note 2	○	○	○	
	TLP190B	4.0	4.0	—	2500	○	—	—	—	—	
	TLP191B	4.0	4.0	—	2500	○	—	—	—	—	
	TLP192A	4.0	4.0	—	1500	○	—	—	—	—	
	TLP192G	4.0	4.0	—	1500	○	—	—	—	—	
	TLP197G	4.0	4.0	—	1500	○	△note 2	○	○	○	
	TLP197GA	4.0	4.0	—	1500	○	—	○	○	○	
	TLP199D	4.0	4.0	—	1500	○	—	—	—	—	
	TLP200D	4.0	4.0	—	1500	○	—	—	—	—	
	TLP202A	4.0	4.0	—	1500	○	—	—	—	—	
	TLP202G	4.0	4.0	—	1500	○	—	—	—	—	
	TLP206A	4.0	4.0	—	1500	○	△note 2	—	—	—	
TLP206G	4.0	4.0	—	1500	○	△note 2	○	○	○		
TLP206GA	4.0	4.0	—	1500	○	—	○	○	○		
TLP209D	4.0	4.0	—	1500	○	—	—	—	—		
TLP222A	7.0	6.4	0.4	2500	○	□	—	—	—		
TLP222A-2	7.0	7.0	0.4	2500	○	□	—	—	—		
TLP222G	7.0	7.0	0.4	2500	○	□	○	○	○		
TLP222G-2	7.0	7.0	0.4	2500	○	□	○	○	○		
TLP224G	7.0	7.0	0.4	2500	○	—	—	—	○		
TLP224G-2	7.0	7.0	0.4	2500	○	—	—	—	○		
TLP224GA	7.0	7.0	0.4	2500	○	—	—	—	○		
TLP224GA-2	7.0	7.0	0.4	2500	○	—	—	—	○		
TLP225A	6.4	6.4	—	2500	○	—	—	—	○		
TLP227A	7.0	7.0	0.4	2500	○	□	—	—	○		
TLP227A-2	7.0	7.0	0.4	2500	○	□	—	—	○		
TLP227G	6.4	6.4	0.4	2500	○	○	○	○	○		
TLP227G-2	6.4	6.4	0.4	2500	○	○	○	○	○		
TLP227GA	7.0	7.0	0.4	2500	○	□	—	—	○		
TLP227GA-2	7.0	7.0	0.4	2500	○	□	—	—	○		
TLP250	6.4	6.4	—	2500	○	○	—	—	—		
TLP250F	8.0	8.0	—	2500	○	○	—	—	—		
TLP251	6.4	6.4	—	2500	○	○	—	—	—		
TLP251F	8.0	8.0	—	2500	○	○	—	—	—		
TLP260J	4.0	4.0	—	3000	○	△note 2	—	—	—		
TLP280	4.0	4.0	0.4	2500	○	△note 2	○	○	○		
TLP280-4	4.0	4.0	0.4	2500	○	△note 2	○	○	○		
TLP281	4.0	4.0	0.4	2500	○	△note 2	○	○	○		
TLP281-4	4.0	4.0	0.4	2500	○	△note 2	○	○	○		
TLP283	4.0	4.0	0.4	2500	○	—	—	—	—		
TLP283-4	4.0	4.0	0.4	2500	○	—	—	—	—		

note 2: VDE (EN60747) standard for MFSOP and SOP photocouplers are different from those of for DIP photocouplers, because MFSOP and SOP are compact and small packages.

This list mentions recommended line ups, and does not cover all products.

- ① DIP single mold
- ② DIP single mold (with Film Isolation)
- ③ DIP double mold
- ④ DIP reflection type
- ⑤ MFSOP single mold
- ⑥ MFSOP double mold
- ⑦ MFSOP/SOP reflection type
- ⑧ SDIP single mold

7 Safety Standard Approved Photocouplers

○, △: Approved —: Not approved □: Under application

as of Sep. 04

	Product number	Construction Mechanical Ratings (min)				UL UL1577	VDE/TUV EN60747	BSI		SEMKO EN60950	Internal Construction
		Isolation Creepage Path (mm)	Isolation Clearance (mm)	Isolation thickness (mm)	Isolation Voltage (mm)			EN60950	EN60065		
TLP 3xx	TLP320	6.4	6.4	—	5000	○	—	—	—	—	①
	TLP320-2	6.4	6.4	—	5000	○	—	—	—	—	
	TLP321	6.4	6.4	—	5000	○	—	—	—	—	
	TLP321-2	6.4	6.4	—	5000	○	—	—	—	—	
	TLP330	6.4	6.4	—	5000	○	—	—	—	—	
	TLP331	6.4	6.4	—	5000	○	—	—	—	—	
	TLP332	6.4	6.4	—	5000	○	—	—	—	—	
	TLP351	6.4	6.4	0.4	3750	○	○	—	—	—	
	TLP351F	8.0	8.0	0.4	3750	○	○	—	—	—	
	TLP360J	7.0	7.0	0.4	5000	○	○	—	—	—	
	TLP360JF	8.0	8.0	0.4	5000	○	○	—	—	—	
	TLP361J	7.0	7.0	0.4	5000	○	○	—	—	—	
	TLP361JF	8.0	8.0	0.4	5000	○	○	—	—	—	
	TLP363J	7.0	7.0	0.4	5000	○	○	—	—	—	
	TLP363JF	8.0	8.0	0.4	5000	○	○	—	—	—	
	TLP371	6.4	6.4	—	5000	○	—	—	—	—	
	TLP372	6.4	6.4	—	5000	○	—	—	—	—	
TLP373	6.4	6.4	—	5000	○	—	—	—	—		
TLP377	6.4	6.4	—	5000	○	—	—	—	—		
TLP 4xx	TLP421	7.0	7.0	0.4	5000	○	○	○	○	④	
	TLP421F	8.0	8.0	0.4	5000	○	○	○	○		
	TLP421F	8.0	8.0	0.4	5000	○	○	○	○		
TLP 5xx	TLP504A	6.4	6.4	—	2500	○	—	—	—	①	
	TLP511GA	6.4	6.4	—	2500	○	—	—	—		
	TLP521-1	6.4	6.4	—	2500	○	—	—	—		
	TLP521-2	6.4	6.4	—	2500	○	—	—	—		
	TLP521-4	6.4	6.4	—	2500	○	—	—	—		
	TLP523	6.4	6.4	—	2500	○	—	—	—		
	TLP523-2	6.4	6.4	—	2500	○	—	—	—		
	TLP525G	6.4	6.4	—	2500	○	—	—	—		
	TLP541G	6.4	6.4	—	2500	○	—	—	—		
	TLP542G	6.4	6.4	—	2500	○	—	—	—		
	TLP543J	6.4	6.4	—	2500	○	—	—	—		
	TLP545J	6.4	6.4	—	2500	○	—	—	—		
	TLP550	6.4	6.4	—	2500	○	—	—	—		
	TLP551	6.4	6.4	—	2500	○	—	—	—		
	TLP552	6.4	6.4	—	2500	○	—	—	—		
	TLP553	6.4	6.4	—	2500	○	—	—	—		
	TLP554	6.4	6.4	—	2500	○	—	—	—		
	TLP555	6.4	6.4	—	2500	○	—	—	—		
	TLP557	6.4	6.4	—	2500	○	—	—	—		
	TLP558	6.4	6.4	—	2500	○	—	—	—		
	TLP559	6.4	6.4	—	2500	○	—	—	—		
	TLP560G	6.4	6.4	—	2500	○	—	—	—		
	TLP560J	6.4	6.4	—	2500	○	—	—	—		
	TLP561G	6.4	6.4	—	2500	○	—	—	—		
	TLP561J	6.4	6.4	—	2500	○	—	—	—		
	TLP570	6.4	6.4	—	2500	○	—	—	—		
	TLP571	6.4	6.4	—	2500	○	—	—	—		
	TLP572	6.4	6.4	—	2500	○	—	—	—		
	TLP590B	6.4	6.4	—	2500	○	—	—	—		
	TLP591B	6.4	6.4	—	2500	○	—	—	—		
	TLP592A	7.0	7.0	0.4	2500	○	—	—	—		
	TLP592G	7.0	7.0	0.4	2500	○	—	—	—		
	TLP594G	6.4	6.4	—	2500	○	—	—	—		
TLP597A	7.0	7.0	0.4	2500	○	—	—	○			
TLP597G	6.4	6.4	0.4	2500	○	○	○	○			
TLP597GA	7.0	7.0	0.4	2500	○	—	—	○			
TLP598AA	7.0	7.0	0.4	2500	○	□	□	□			
TLP598GA	7.0	7.0	0.4	2500	○	□	□	□			

This list mentions recommended line ups, and does not cover all products.

- ① DIP single mold ② DIP single mold (with Film Isolation) ③ DIP double mold ④ DIP reflection type
 ⑤ MFSOP single mold ⑥ MFSOP double mold ⑦ MFSOP/SOP reflection type ⑧ SDIP single mold

	Product number	Construction Mechanical Ratings (min)				UL UL1577	VDE/TUV EN60747	BSI		SEMKO EN60950	Internal Construction
		Isolation Creepage Path (mm)	Isolation Clearance (mm)	Isolation thickness (mm)	Isolation Voltage (mm)			EN60950	EN60065		
TLP 6xx	TLP611J	6.4	6.4	—	5000	○	—	—	—	—	②
	TLP620	6.4	6.4	0.4	5000	○	○	○	○	○	
	TLP620-2	6.4	6.4	0.4	5000	○	○	○	○	○	
	TLP620-4	6.4	6.4	0.4	5000	○	○	○	○	○	
	TLP620F	8.0	8.0	0.4	5000	○	○	○	○	○	
	TLP620F-2	8.0	8.0	0.4	5000	○	○	○	○	○	
	TLP620F-4	8.0	8.0	0.4	5000	○	○	○	○	○	
	TLP621	6.4	6.4	0.4	5000	○	○	○	○	○	
	TLP621-2	6.4	6.4	0.4	5000	○	○	○	○	○	
	TLP621-4	6.4	6.4	0.4	5000	○	○	○	○	○	
	TLP621F	8.0	8.0	0.4	5000	○	○	○	○	○	
	TLP621F-2	8.0	8.0	0.4	5000	○	○	○	○	○	
	TLP621F-4	8.0	8.0	0.4	5000	○	○	○	○	○	
	TLP624	6.4	6.4	—	5000	○	—	○	○	—	
	TLP624-2	6.4	6.4	—	5000	○	—	○	○	—	
	TLP624-4	6.4	6.4	—	5000	○	—	○	○	—	
	TLP626	6.4	6.4	—	5000	○	—	○	○	—	
	TLP626-2	6.4	6.4	—	5000	○	—	○	○	—	
	TLP626-4	6.4	6.4	—	5000	○	—	○	○	—	
	TLP627	6.4	6.4	0.4	5000	○	○	○	○	○	
	TLP627-2	6.4	6.4	0.4	5000	○	○	○	○	○	
	TLP627-4	6.4	6.4	—	5000	○	○	○	○	○	
	TLP627F	8.0	8.0	0.4	5000	○	○	○	○	○	
	TLP627F-2	8.0	8.0	0.4	5000	○	○	○	○	○	
	TLP627F-4	8.0	8.0	—	5000	○	○	○	○	○	
	TLP628	6.4	6.4	—	5000	○	—	○	○	—	
	TLP628-2	6.4	6.4	—	5000	○	—	○	○	—	
	TLP628-4	6.4	6.4	—	5000	○	—	○	○	—	
	TLP629	6.4	6.4	—	5000	○	—	○	○	—	
	TLP629-2	6.4	6.4	—	5000	○	—	○	○	—	
TLP629-4	6.4	6.4	—	5000	○	—	○	○	—		
TLP630	6.4	6.4	—	5000	○	—	—	—	—		
TLP631	6.4	6.4	—	5000	○	—	—	—	—		
TLP632	6.4	6.4	—	5000	○	—	—	—	—		
TLP641G	6.4	6.4	—	5000	○	—	—	—	—		
TLP665G(S)	7.0	7.0	0.5	5000	○	○	○	○	○		
TLP665GF(S)	8.0	8.0	0.5	5000	○	○	○	○	○		
TLP665J(S)	7.0	7.0	0.5	5000	○	○	○	○	○		
TLP665JF(S)	8.0	8.0	0.5	5000	○	○	○	○	○		
TLP666G(S)	7.0	7.0	0.5	5000	○	○	○	○	○		
TLP666GF(S)	8.0	8.0	0.5	5000	○	○	○	○	○		
TLP666J(S)	7.0	7.0	0.5	5000	○	○	○	○	○		
TLP666JF(S)	8.0	8.0	0.5	5000	○	○	○	○	○		
TLP668J(S)	7.0	7.0	0.5	5000	○	○	○	○	○		
TLP668JF(S)	8.0	8.0	0.5	5000	○	○	○	○	○		
TLP 7xx	TLP701	8.0	7.0	0.4	5000	○	○	—	—	—	⑧
	TLP701F	8.0	8.0	0.4	5000	○	○	—	—	—	
	TLP705	7.0	7.0	0.4	5000	○	—	—	—	—	
	TLP705F	8.0	8.0	0.4	5000	○	—	—	—	—	
	TLP719	7.0	7.0	0.4	5000	○	○	—	—	—	③
	TLP719F	8.0	8.0	0.4	5000	○	○	—	—	—	
	TLP722	7.0	7.0	0.4	4000	○	—	—	—	—	②
	TLP722F	8.0	8.0	0.4	4000	○	—	—	—	—	
	TLP741G	7.0	7.0	0.5	4000	○	○	○	○	○	③
	TLP741J	7.0	7.0	0.5	4000	○	○	○	○	○	
	TLP747G	7.0	7.0	0.5	4000	○	○	○	○	○	②
	TLP747GF	8.0	8.0	0.5	4000	○	○	○	○	○	
	TLP747J	7.0	7.0	0.5	4000	○	○	○	○	○	③
	TLP747JF	8.0	8.0	0.5	4000	○	○	○	○	○	
	TLP750	6.4	6.4	0.4	5000	○	○	○	○	○	②
	TLP750F	8.0	8.0	0.4	5000	○	○	○	○	○	
	TLP751	6.4	6.4	0.4	5000	○	○	○	○	○	
	TLP759	6.4	6.4	0.4	5000	○	○	○	○	○	
	TLP759F	8.0	8.0	0.4	5000	○	○	○	○	○	③
	TLP762J	7.0	7.0	0.5	4000	○	○	○	○	○	
	TLP762JF	8.0	8.0	0.5	4000	○	○	○	○	○	
	TLP763J	7.0	7.0	0.5	4000	○	○	○	○	○	②
TLP763JF	8.0	8.0	0.5	4000	○	○	○	○	○		
TLP797GA	7.0	7.0	0.4	5000	○	○	□	□	□	③	
TLP797GAF	8.0	8.0	0.4	5000	○	○	□	□	□		
TLP797J	7.0	7.0	0.4	5000	○	○	□	□	□		
TLP797JF	8.0	8.0	0.4	5000	○	○	□	□	□		
TLP798GA	7.0	7.0	0.4	5000	○	□	□	□	□	②	
TLP798GAF	8.0	8.0	0.4	5000	○	□	□	□	□		

This list mentions recommended line ups, and does not cover all products.

- ① DIP single mold
- ② DIP single mold (with Film Isolation)
- ③ DIP double mold
- ④ DIP reflection type
- ⑤ MFSOP single mold
- ⑥ MFSOP double mold
- ⑦ MFSOP/SOP reflection type
- ⑧ SDIP single mold

7 Safety Standard Approved Photocouplers

O, Δ: Approved —: Not approved □: Under application

as of Sep. 04

	Product number	Construction Mechanical Ratings (min)				UL UL1577	VDE/TUV EN60747	BSI		SEMKO EN60950	Internal Construction
		Isolation Creepage Path (mm)	Isolation Clearance (mm)	Isolation thickness (mm)	Isolation Voltage (mm)			EN60950	EN60065		
TLP 2xxx	TLP2530	6.4	6.4	—	2500	○	—	—	—	—	①
	TLP2531	6.4	6.4	—	2500	○	—	—	—	—	
	TLP2630	6.4	6.4	—	2500	○	—	—	—	—	
	TLP2631	6.4	6.4	—	2500	○	—	—	—	—	
TLP 3xxx	TLP3110	4.0	4.0	—	1500	○	—	—	—	—	⑤
	TLP3111	4.0	4.0	—	1500	○	—	—	—	—	
	TLP3113	4.0	4.0	—	1500	○	—	—	—	—	
	TLP3114	4.0	4.0	—	1500	○	—	—	—	—	
	TLP3115	4.0	4.0	—	1500	○	—	—	—	—	
	TLP3116	4.0	4.0	—	1500	○	—	—	—	—	
	TLP3120	4.0	4.0	—	1500	○	—	—	—	—	
	TLP3121	4.0	4.0	—	1500	○	—	—	—	—	
	TLP3130	4.0	4.0	—	1500	○	—	—	—	—	
	TLP3131	4.0	4.0	—	1500	○	—	—	—	—	
	TLP3502	6.4	6.4	—	2500	○	—	—	—	—	
	TLP3502A	6.4	6.4	—	2500	○	—	—	—	—	
	TLP3503	6.4	6.4	—	2500	○	—	—	—	—	
	TLP3506	6.4	6.4	—	2500	○	—	—	—	—	
TLP3507	6.4	6.4	—	2500	○	—	—	—	—		
TLP3520	6.4	6.4	—	2500	○	—	—	—	—		
TLP3520A	6.4	6.4	—	2500	○	—	—	—	—		
TLP3521	6.4	6.4	—	2500	○	—	—	—	—		
TLP3526	6.4	6.4	—	2500	○	—	—	—	—		
TLP3527	6.4	6.4	—	2500	○	—	—	—	—		
TLP3530	6.4	6.4	—	2500	○	—	—	—	—		
TLP3540	4.0	4.0	—	1500	○	—	—	—	—		
TLP3542	6.4	6.4	—	2500	○	—	—	—	—		
TLP3616	6.4	6.4	0.4	2500	○	—	—	—	—		
TLP3617	6.4	6.4	0.4	2500	○	—	—	—	—		
TLP4006G	7.0	7.0	0.4	2500	○	—	—	—	—		
TLP4007G	7.0	7.0	0.4	2500	○	—	—	—	—		
TLP4026G	4.0	4.0	—	1500	○	—	—	—	—		
TLP4027G	4.0	4.0	—	1500	○	—	—	—	—		
TLP4172G	4.0	4.0	—	1500	○	—	—	—	—		
TLP4176G	4.0	4.0	—	1500	○	—	—	—	—		
TLP4192G	4.0	4.0	—	1500	○	—	—	—	—		
TLP4197G	4.0	4.0	—	1500	○	—	—	—	—		
TLP4202G	4.0	4.0	—	1500	○	—	—	—	—		
TLP4206G	4.0	4.0	—	1500	○	—	—	—	—		
TLP4222G	7.0	7.0	0.4	2500	○	—	—	—	—		
TLP4222G-2	7.0	7.0	0.4	2500	○	—	—	—	—		
TLP4227G	7.0	7.0	0.4	2500	○	—	—	—	—		
TLP4227G-2	7.0	7.0	0.4	2500	○	—	—	—	—		
TLP4592G	7.0	7.0	0.4	2500	○	—	—	—	—		
TLP4597G	7.0	7.0	0.4	2500	○	—	—	—	—		

This list mentions recommended line ups, and does not cover all products.

- ① DIP single mold ② DIP single mold (with Film Isolation) ③ DIP double mold ④ DIP reflection type
⑤ MFSOP single mold ⑥ MFSOP double mold ⑦ MFSOP/SOP reflection type ⑧ SDIP single mold

7.1 Internal Construction

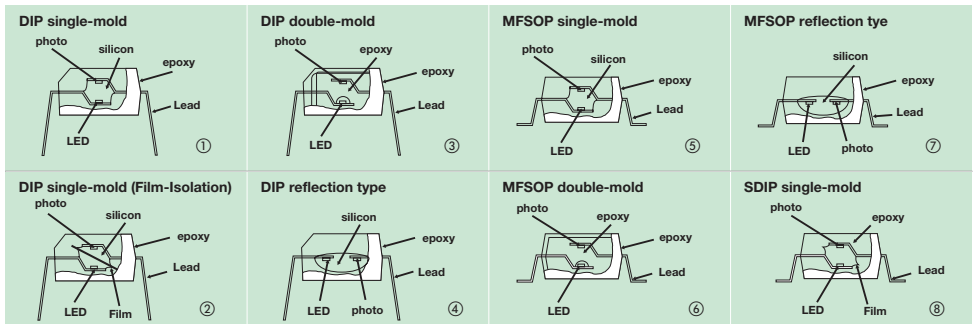

8 Photocoupler Application Circuit Example

8.1 Digital Interface Applications

High Speed

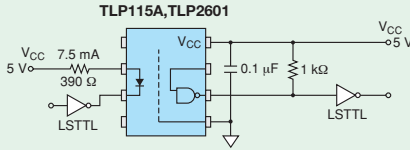

By using the high-speed TLP2601 device, (the equivalent MFC⁽¹⁾ version is the TLP115A) high-speed data transmission is possible up to approximately 5 MHz.
 $f(\text{typ.}): 5 \text{ Mbit/s}$ (Duty cycle $\approx 1/2$)

Low Input Current Drive

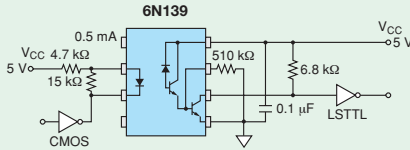

Use of the high-CTR (current transfer ratio) 6N139 enables operation by low input current (0.5 mA), and direct driving with a CMOS.
 $f(\text{typ.}): 50 \text{ kbit/s}$ (Duty cycle $\approx 1/2$)

Pull-up Resistor Replacement

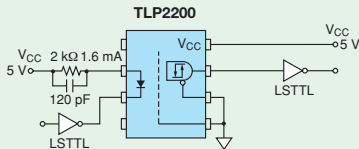

When the 3-state-output TLP2200 is used, the next-step logic gate can be actuated without using a pull-up resistor.
 $f(\text{typ.}): 1 \text{ Mbit/s}$ (Duty cycle $\approx 1/2$)

High VCC Tolerance

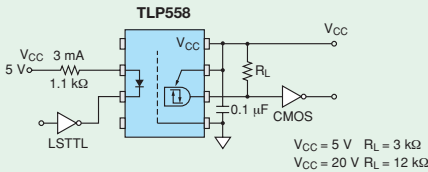

By using the TLP558 which accepts a wide range of V_{CC} (up to 20 V), the CMOS logic gates and other components can be operated with high V_{CC} .
 $f(\text{typ.}): 1 \text{ Mbit/s}$ (Duty cycle $\approx 1/2$)

8 Photocoupler Application Circuit Example

8.2 Inverter and AC / DC Servo Applications

[Photo-IC coupler, high-speed base/gate drive circuit application]

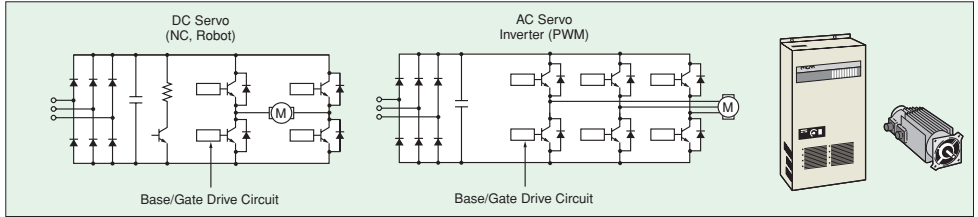
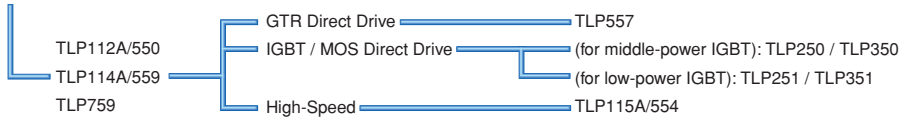

15-A Class GTR (Giant Transistor) Module Base Drive

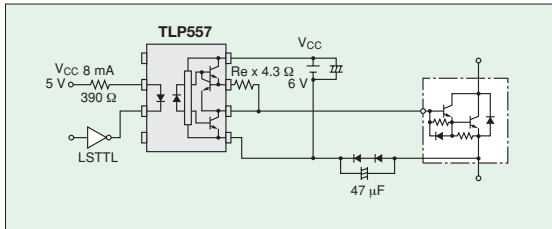

The TLP557 drives a GTR base directly. An external resistor R_{ex} is connected between pins 6 and 7. This resistor causes the drive base current to become constant and stabilizes the GTR drive.

100-A Class GTR Module Base Drive

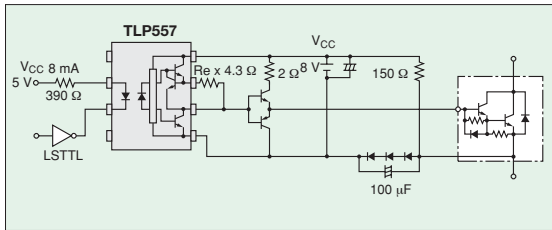

The TLP557 photo-IC coupler and two booster transistors can drive a high-power GTR.

15-A Class IGBT (Insulated Gate Bipolar Transistor) Module Gate Drive

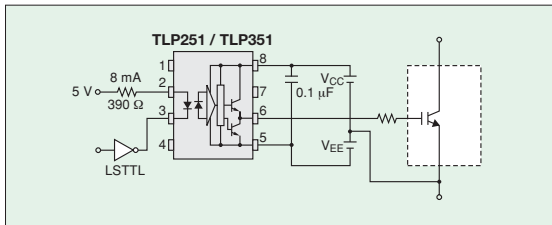

The TLP251 / 351 high-speed photo-IC photocoupler can drive a low power IGBT directly.

3.2 Inverter and AC / DC Servo Applications (continued)

50-A Class IGBT Module Gate Drive

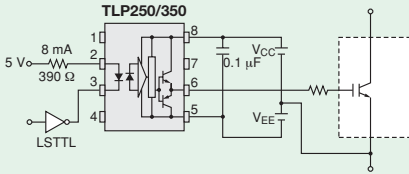

The TLP250 / 350 can drive a medium power IGBT directly.

400-A Class IGBT Module Gate Drive

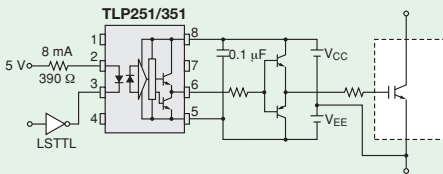

The TLP251 / 351 high-speed photo-IC photocoupler and two booster transistors can drive a high power IGBT.

IGBT Module Gate Drive Using (IGM) Selection

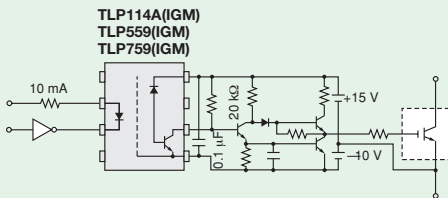

The (IGM) selection is suitable to drive an IPM (Intelligent Power Module). The device has a guaranteed propagation delay difference $|t_{PLH} - t_{PHL}|$ and provides a high common transient immunity.

(IGM) Selection

Part Number	Package Type	BVs (Vrms)	V _o /V _{cc}	CTR	$ t_{PLH} - t_{PHL} $	CMH	CML
TLP114A (IGM)	MFSOP6	3750	20 V / 30 V max	25 % min 75 % max @I _F = 10 mA V _{CC} = 4.5 V V _O = 0.4 V	0.7 μs max @I _F = 10 mA R _L = 20 kΩ	10000 V / μs min @I _F = 0 mA R _L = 20 kΩ V _{CM} = 1500 V _{p-p}	—10000 V / μs min @I _F = 10 mA R _L = 20 kΩ V _{CM} = 1500 V _{p-p}
TLP559 (IGM)	DIP8	2500					
TLP759 (IGM)	DIP8	5000					

8 Photocoupler Application Circuit Example

8.3 TV and Audio Applications

Application for "MIDI" Interface for Electronic Musical Instrument

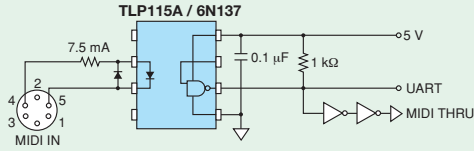

Application for Compact Disc Player

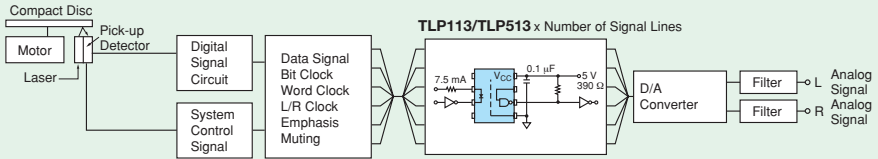

Application for TV/AV Terminal Isolation

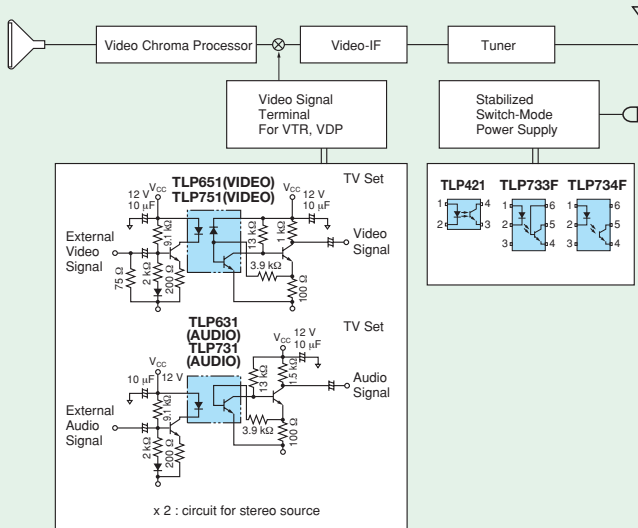

Part Number	Isolation Voltage	Band Width	Voltage Gain
TLP651 (VIDEO)	5000 Vrms	> 4.5 MHz	0.5 to 2
TLP751 (VIDEO)	5000 Vrms		0.4 to 1.8
TLP631 (AUDIO)	5000 Vrms	> 100 kHz	0.7 to 2
TLP731 (AUDIO)	4000 Vrms		

8.4 Home Appliance Applications

Oven/Grill Set Application

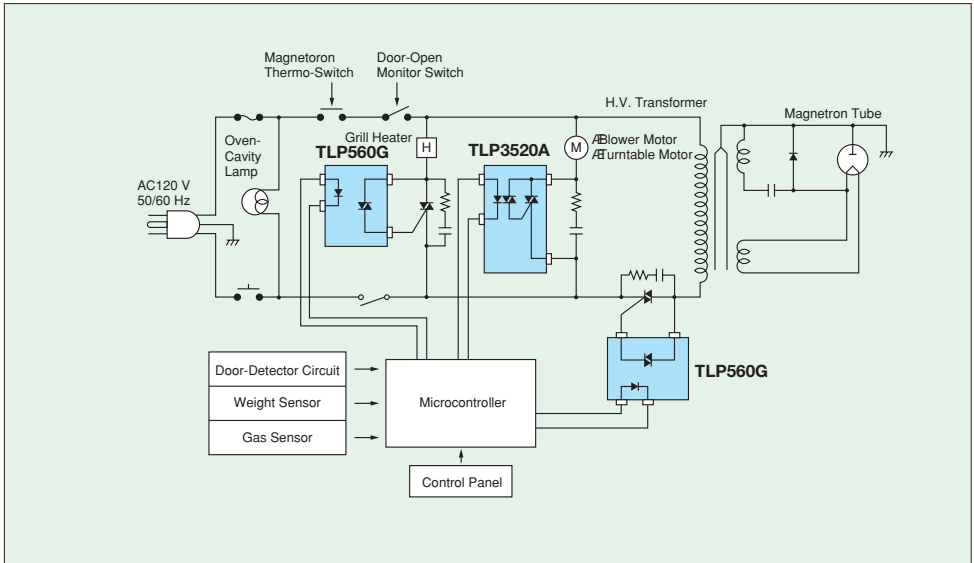

Block Diagram for Refrigerator Application

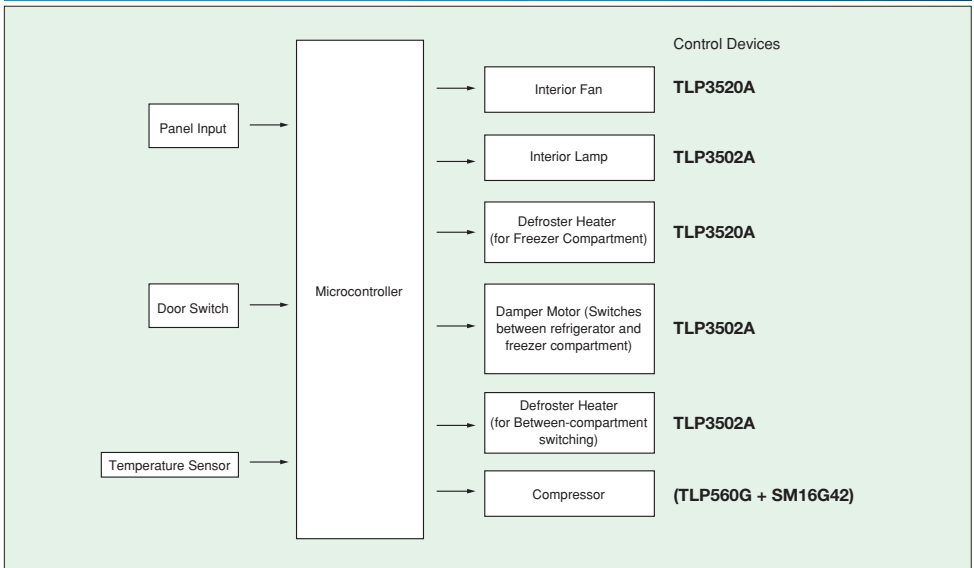

8 Photocoupler Application Circuit Example

8.4 Home Appliance Applications (continued)

Automatic Washing Machine Application

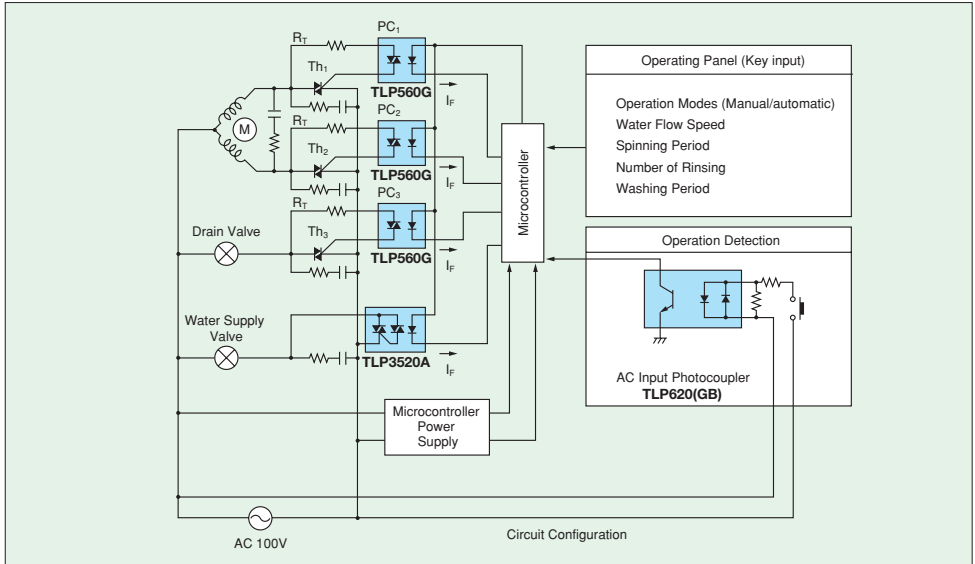

Application for Fan Heater

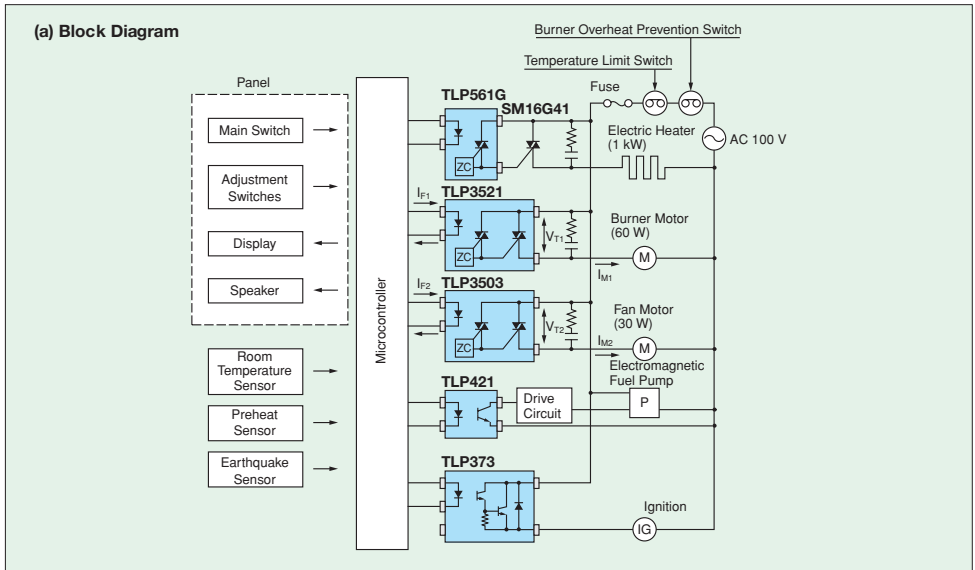

3.4 Home Appliance Applications (continued)

(b) Waveform Examples

1. Example of Operating Waveform for Burner Motor

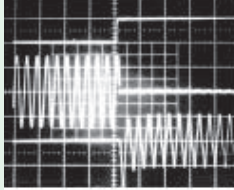

Trigger Point

Top:	I_{F1}	20 mA/div
Medium:	V_{T1}	100 V/div
Bottom:	I_{M1}	1 A/div
Horizontal:	time	50 ms/div

2. Example of Operating Waveform for Fan Motor

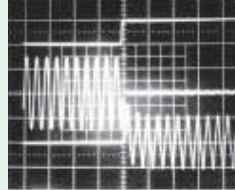

Trigger Point

Top:	I_{F2}	20 mA/div
Medium:	V_{T2}	100 V/div
Bottom:	I_{M2}	0.5 A/div
Horizontal:	time	50 ms/div

Application for Inverter Air Conditioner

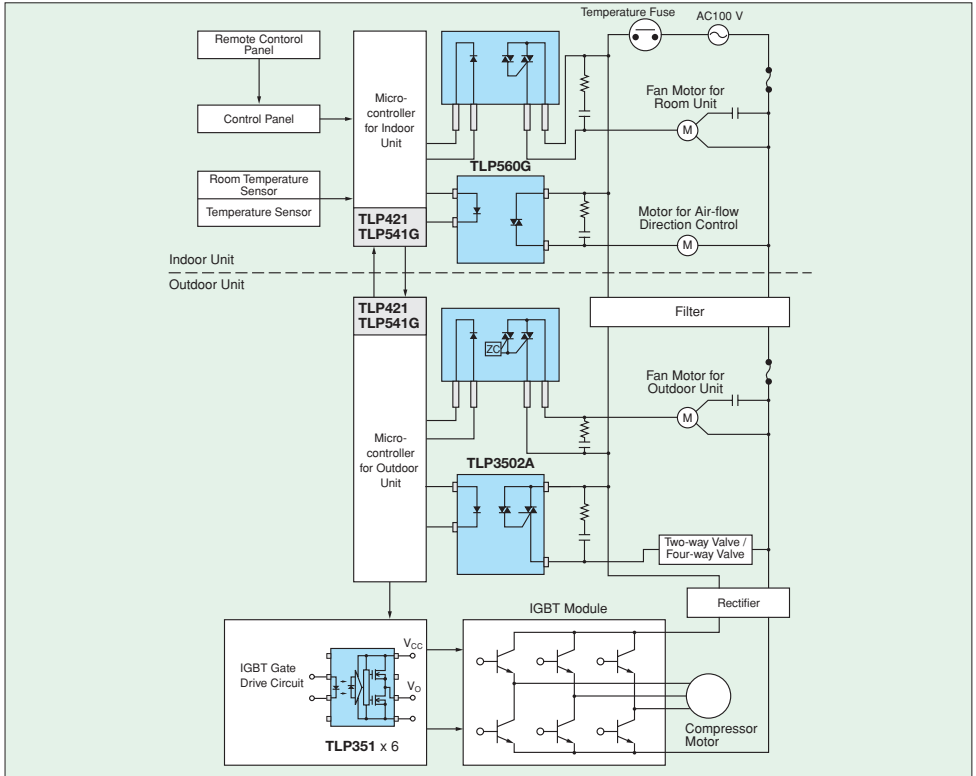

8 Photocoupler Application Circuit Example

8.5 Programmable Controller Applications

DC Output for Sequencer

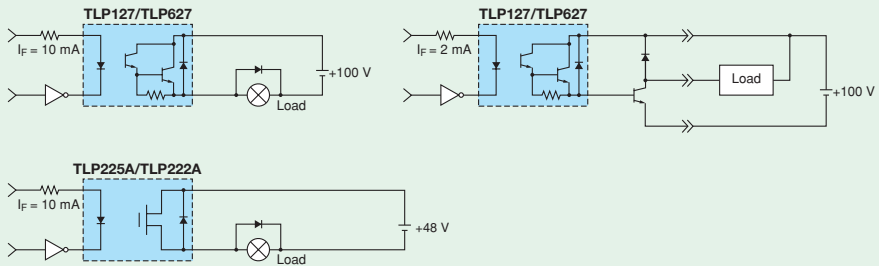

AC Input for Sequencer

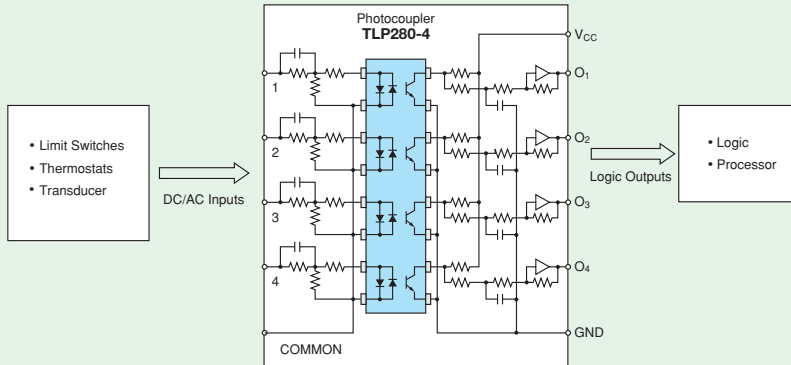

120-/240-V AC Output for Sequencer and SSR

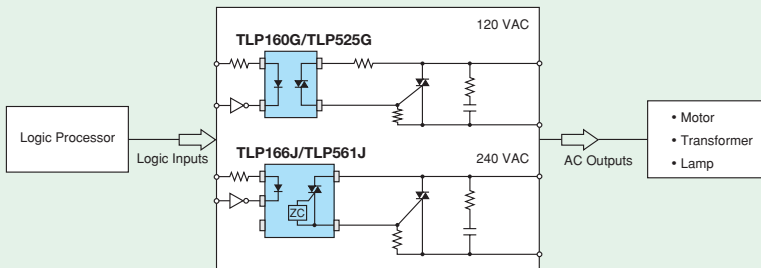

8.6 SSR and Power Control Circuit Applications

Zero-Crossing Phototriac Output Device Application: TLP561G/TLP561J and Mini-flatTLP161G/TLP166J

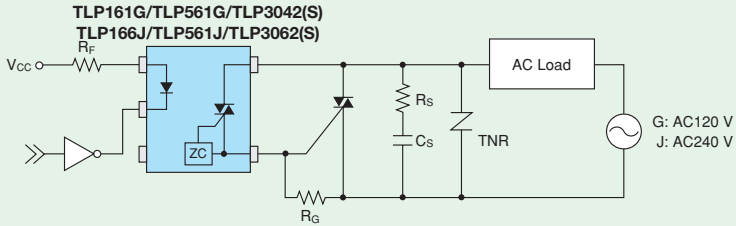

Lamp Load (1-A tungsten lamp)



Waveforms {
 Top: I_F 20 mA/div
 Medium: V_T 100 V/div
 Bottom: I_T 5 A/div

L load (2.5-A pure inductive load)



Recommended conditions {
 $I_F = 20$ mA
 $R_G = 47 \Omega$
 $R_S = 47 \Omega$, $C_S = 0.033 \mu\text{F}$

Non-Zero Crossing Phototriac Output Device Application: TLP560G/TLP560J and Mini-flatTLP160G/TLP165J

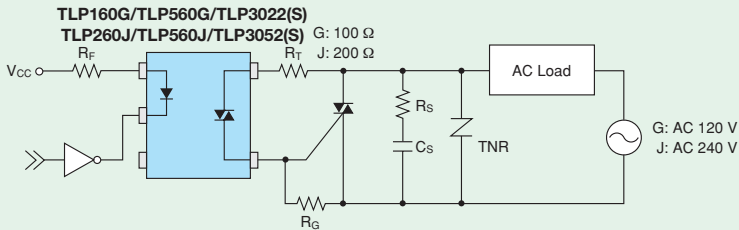

Lamp Load (1-A tungsten lamp)

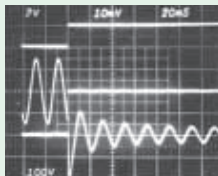

Waveforms {
 Top: I_F 20 mA/div
 Medium: V_T 100 V/div
 Bottom: I_T 5 A/div

L load (2.5-A pure inductive load)

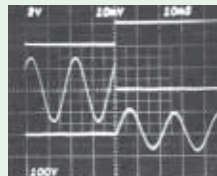

Recommended conditions {
 $I_F = 20$ mA
 $R_T = 100 \Omega/200 \Omega$
 $R_G = 47 \Omega$
 $R_S = 47 \Omega$, $C_S = 0.033 \mu\text{F}$

8 Photocoupler Application Circuit Example

8.7 Switching Power Supply Circuit Application

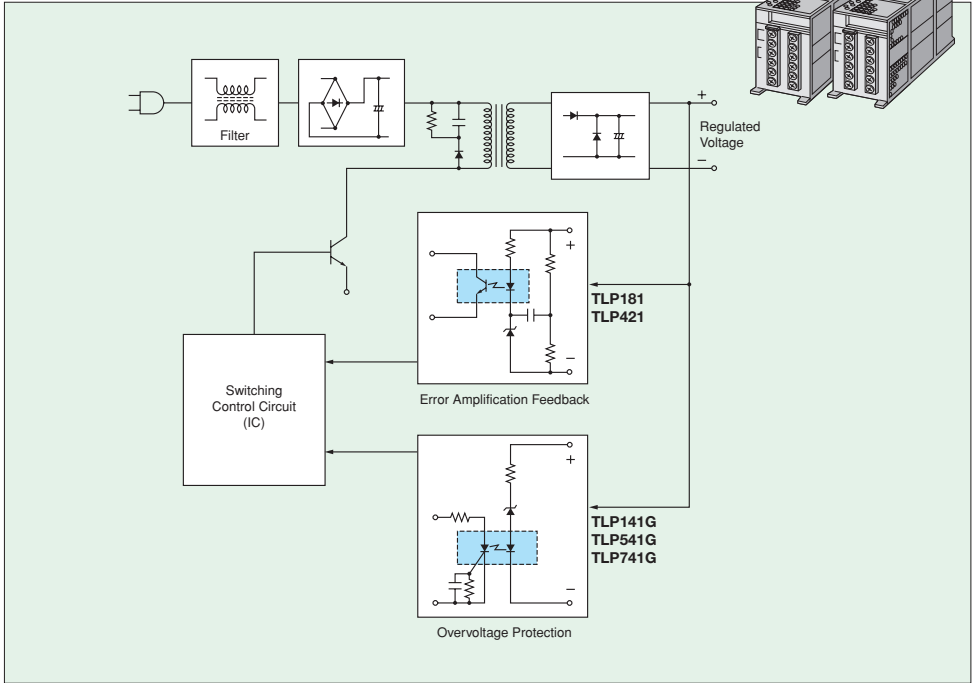

● Transistor Output (○: Approved, △: Design which meets safety standards, as of March 2003)

Part Number	Package Type	Isolation Voltage	Safety Standard Approvals				CTR (I _c / I _F) Rank (%)		
			UL 1577	BSI 7002 (EN60950)	VDE 0884 (Note 1)	Nordic SEMKO		Min	Max
TLP181	Min flat	3750 Vrms	○	○	△(Note 2)	○	No Rank	50	600
TLP421	DIP4	5000 Vrms	○*	○	○	○	(GB) Rank	100	600
							(Y) Rank	50	150
							(GR) Rank	100	300
							(BL) Rank	200	600
							(GRL) Rank	100	200
TLP750 (high-speed)	DIP8	5000 Vrms	○	○	○	○	(GRH) Rank	150	300
							(O) Rank	19	—
							No Rank	10	—

Note 2: VDE0884 standards for mini-flat photocoupler are different from those for standard DIP photocouplers because mini-flat package is compact and small.

● Thyristor Output

Part Number	Package Type	Isolation Voltage	Safety Standard Approvals				I _{FT} (mA)	V _{DRM} (V)
			UL 1577	BSI 7002 (EN60950)	VDE 0884 (Note 1)	Nordic SEMKO		
TLP141G	Min flat	2500 Vrms	○				10	400
TLP541G	DIP6		○				7	
TLP741G			4000 Vrms	○	○	○	○	10

Note 1: VDE0884-approved with option (D4)

8.8 Push-Button Telephone Application

A variety of photocouplers are used to isolate between telephone lines (L1 and L2) and CPU.

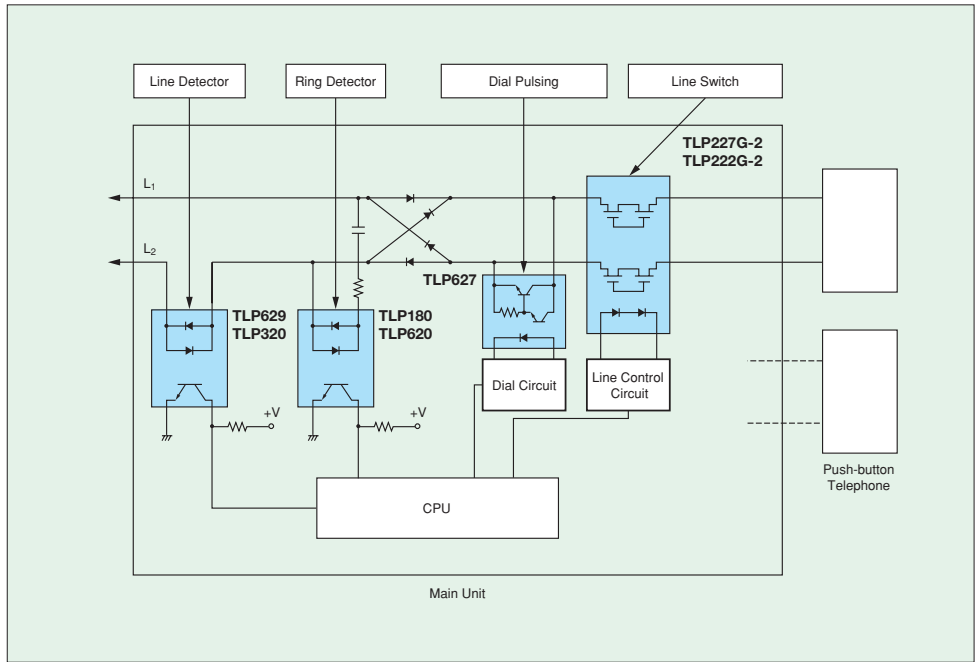

Application	Package Type	Part Number		Features
		DC Input	AC Input	
Ring Detector	DIP4	TLP421	TLP620	General single transistor output in compact packages Good cost performance
	Min flat	TLP181, TLP281	TLP180/280	
Dial Pulsing	DIP4	TLP627		High $V_{CE0} = 300$ V Darlington transistor output in compact packages Suitable to generate pulse dial signal High $V_{CE0} = 350$ V single transistor output.
	Min flat	TLP127		
	DIP4	TLP628		
Line Detector	DIP4	TLP629	TLP320	High LED current rating 150 mA Directly connectable in telephone line
Line Switch	DIP4	TLP222G*, TLP227G*		V _{OFF} = 400 V. MOSFET output photorelay Crosspoint relay replacement (*: V _{OFF} = 350 V, **: V _{OFF} = 200 V)
	DIP6	TLP592G*, TLP597G*		
	DIP8 (Dual)	TLP222G-2*, TLP227G-2*		
	2.54SOP4	TLP172G*, TLP176D**, TLP176G*		
	2.54SOP6	TLP192G*, TLP197G*		
	2.54SOP8 (Dual)	TLP200D**, TLP202G*, TLP206G*		

8 Photocoupler Application Circuit Example

8.9 Photovoltaic Coupler Applications

	<p>This is the simplest power MOSFET drive circuit. Resistor RSH for discharging the gate capacitor reduces turn-OFF time. This RSH is not required on the TLP591B which has a built-in resistor. (TON, TOFF = several ms)</p>
	<p>Drives for both AC and DC become possible by connecting power MOSFETs in a source common configuration.</p>
<p>Transformerless AC/DC converter</p>	<p>Photovoltaic couplers in parallel and serial configuration convert AC power to DC without a transformer. This type of configuration requires scores to hundreds of photovoltaic couplers.</p>

8.10 Photorelay for Tester Application

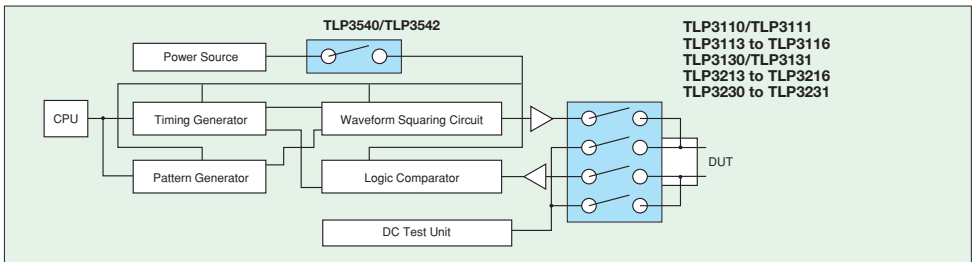

8.11 Photorelay (MOSFET Output) Application

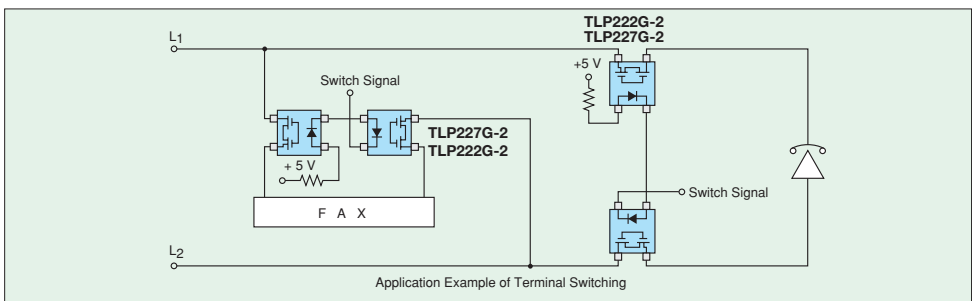

8.12 NCU Circuit (FAX Modem Card) Application

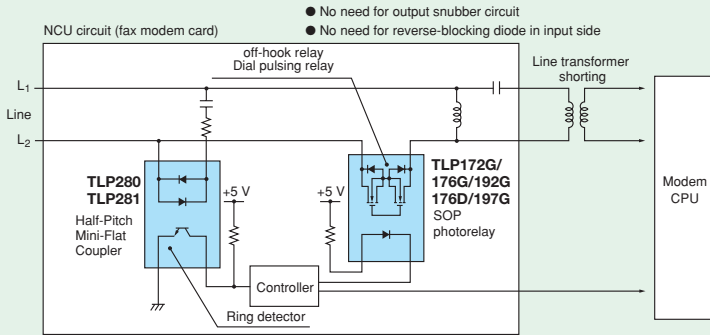

8.13 High-Speed Photo-IC Coupler Applications

















Listed below are typical values.

	Dual Type	6-Pin Type	Mini-Flat Type	Output	Speed	Input Current I _F	Supply Voltage V _{CC}	Supply Current I _{CC}	CMR	Features	Applications	
				±0.5 A	0.2 μs	5 mA	10 to 35 V	10 mA	○	IGBT/Power MOSFET direct gate drive	<ul style="list-style-type: none"> ● General-purpose inverters ● Inverter air conditioners ● AC servo motor control ● IGBT/MOSFET drive 	
				±0.1 A	0.3 μs							
				±0.2 A	0.2 μs	5 mA	10 to 35 V	2 mA				
				-0.25/0.5 A	1 μs	5 mA	16 V or less	10 mA	○	Constant-current base drive, 15-A GTR direct drive	<ul style="list-style-type: none"> ● General-purpose inverters ● Inverter air conditioners ● AC servo motor control ● GTR base drive 	
				3-state output	5 Mbit/s	1.6 mA	4.5 to 20 V	5 mA	○	Inverter logic Input 1 0 ↓ ↓ 0 1 Output	3-state output	<ul style="list-style-type: none"> ● Computer data bus drivers ● High-speed digital signal interfaces ● High-speed gate drive for power MOSFETs ● Various industrial control equipment
									○	Buffer logic Input 1 0 ↓ ↓ 1 0 Output		

8 Photocoupler Application Circuit Example

8.13 High-Speed Photo-IC Coupler Applications (continued)

Listed below are typical values.

	Dual Type	6-Pin Type	SDIP	Mini-Flat Type	Output	Speed	Input Current I _F	Supply Voltage V _{CC}	Supply Current I _{CC}	CMR	Features	Applications
					Open collector	10 Mbit/s	5 mA	5 V	12 mA (24 mA for dual type)	○	Internal noise shield, high CMR version of TLP552 and TLP2630	<ul style="list-style-type: none"> ● NC machines ● Industrial robots ● General-purpose meters ● AC servo motor control ● Computer terminal devices ● Various industrial control equipment ● Electrostatic printers
					Totem pole	20 Mbit/s	5 mA	5 V	2 mA	○	Ultra-low power consumption, high-speed operation	<ul style="list-style-type: none"> ● PDPs ● Measuring instruments ● FA ● Control equipment ● OA equipment
					Open collector	10 Mbit/s	5 mA	5 V	12 mA (24 mA for dual type)	—	High-speed logic output	<ul style="list-style-type: none"> ● Electronic devices ● CD players ● High-speed digital signal interfaces ● Computer terminal devices
					Open collector	0.3 Mbit/s	0.5 mA	18 V or less	0.1 mA	—	Low current drive	<ul style="list-style-type: none"> ● CMOS direct drive ● Current loop receiver/drivers ● Telephone ring detectors ● Computer terminal devices
											Photodiode/phototransistor separated, general-purpose transistor output device	<ul style="list-style-type: none"> ● CCTV video signal isolation ● Analog signal transmission ● Digital signal interfaces
					Open collector	1 Mbit/s	16 mA	15 V or less	0.1 mA (0.2 mA for dual type)	○		<ul style="list-style-type: none"> ● General-purpose inverters ● Inverter air conditioners ● AC servo motor control ● NC machines ● Switching power supply units
								30 V or less		○	Internal noise shield, high CMR version of TLP550	

*: SDIP version of the TLP559/759

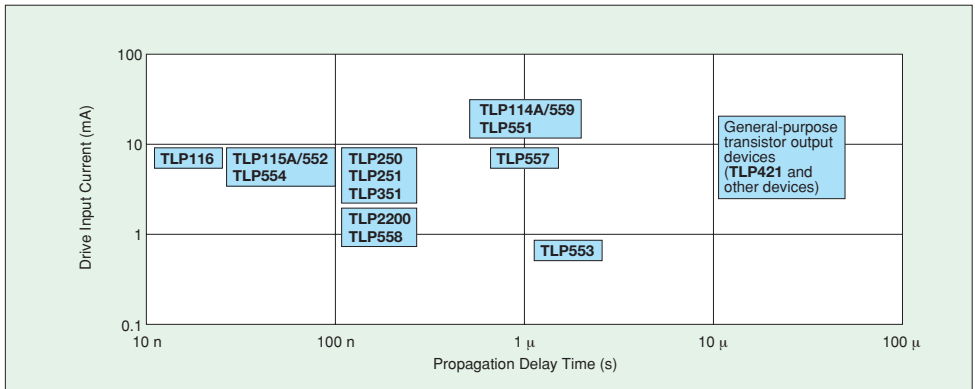

8.13 High-Speed Photo-IC Coupler Applications (continued)

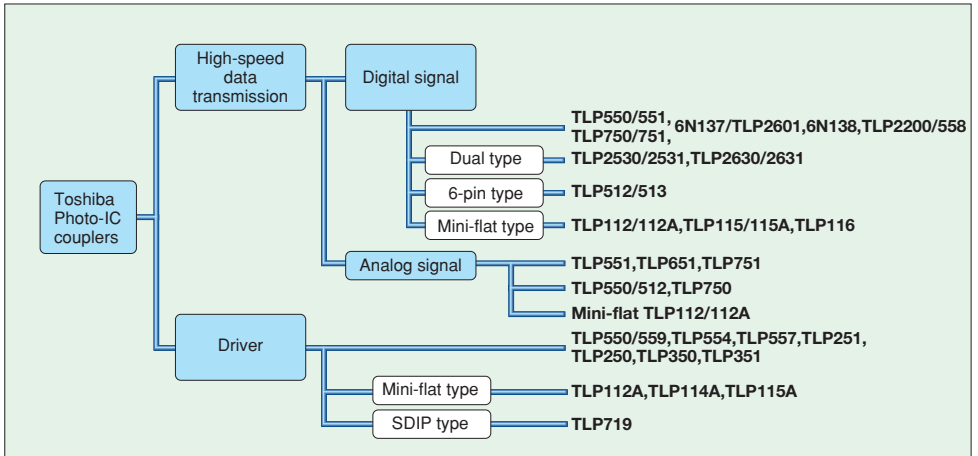

8 Photocoupler Application Circuit Example

8.14 Photorelay Applications

Package (number of channels, contact type)							Off voltage V_{OFF} Max	On current I_{ON} Max	Trigger current I_{FT} Typ.	Features	Applications
SSOP4(1ch,a)	SOP4(1ch,a)	SOP6(1ch,a)	SOP8(2ch,a)	DIP4(1ch,a)	DIP6(1ch,a)	DIP8(2ch,a)	60 V	0.3 to 0.5 A	1 to 2 mA	High on-resistance High-current output	<ul style="list-style-type: none"> Programmable controllers Relay output I/O boards Industrial robots Measuring instruments Gate drive for thyristor
	TLP176A TLP172A	TLP197A TLP192A	TLP206A TLP202A	TLP225A TLP227A TLP222A	TLP597A TLP592A	TLP227A-2 TLP222A-2					
	TLP176D	TLP197D	TLP200D				200 V	0.15 A	1 to 2 mA	FA switching	<ul style="list-style-type: none"> Digital line cards Industrial robots Relay output I/O boards
	TLP176G TLP172G	TLP197G TLP192G	TLP206G TLP202G	TLP227G TLP222G	TLP594G TLP597G TLP592G	TLP222G-2 TLP227G-2	350 V	0.12 A	1 to 2 mA	High breakdown voltage Communication line switching Supports UL1950	<ul style="list-style-type: none"> Public phone line cards Analog modems STBs Various actuator drivers
	TLP176GA	TLP197GA	TLP206GA	TLP227GA	TLP597GA TLP798G TLP797GA	TLP227GA-2	400 V	0.12 A/ 0.15 A	1 to 2 mA	High breakdown voltage Communication line switching Supports UL1950	<ul style="list-style-type: none"> Public phone line cards Analog modems STBs Various actuator drivers
					TLP797J		600 V	0.1 A	1 to 2 mA	High breakdown voltage Communication line switching Supports UL1950	<ul style="list-style-type: none"> Public phone line cards Analog modems STBs Various actuator drivers
TLP3214 TLP3215 TLP3231	TLP3110 TLP3114 TLP3115 TLP3131						20 to 60 V	0.25 to 0.45 A	2 to 3 mA	Low on-resistance for IC tester/measuring instrument Low CR products/ high current	<ul style="list-style-type: none"> Memory testers Logic testers Measuring instruments
TLP3213 TLP3216 TLP3217 TLP3230	TLP3111 TLP3113 TLP3116 TLP3130						20 to 80 V	0.08 to 0.12 A	2 to 3 mA	Low on-resistance for IC testers/measuring instruments $C_{OFF} = 15$ pF Low CR product	<ul style="list-style-type: none"> Memory testers Logic testers Measuring instruments

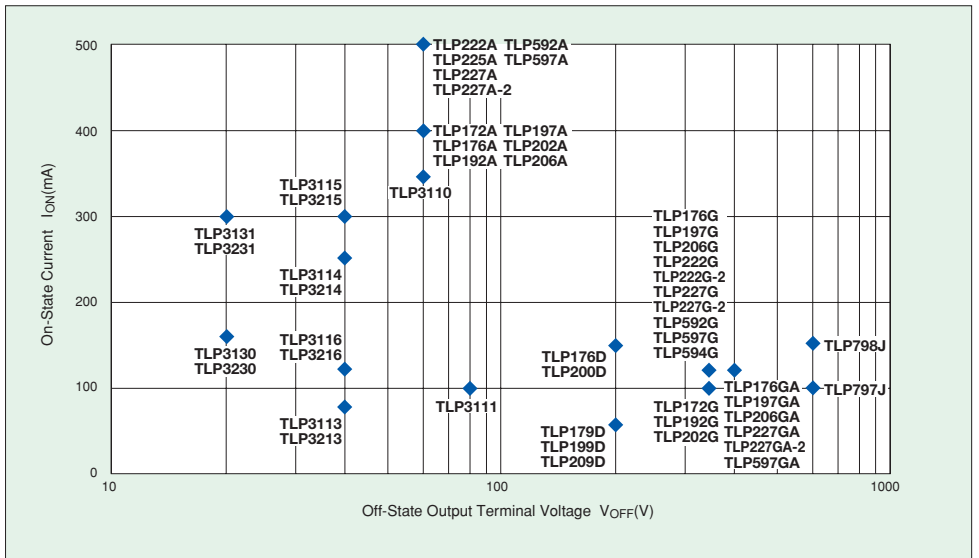

9 Competitor Cross Reference

9.1 Photocouplers

Fairchild

Part Number	TOSHIBA Part Number	Lv
H11A617	TLP421	B
H11A817	TLP421	A
H11AA814	TLP620(T)	B
H11B815	TLP627(T)	A
HMA121	TLP181(T)	A
HMA124	TLP124	A
HMA2701	TLP181(T)	A
HMHA2801	TLP281	A
HMHA281	TLP281	A
HMAA2705	TLP180(T)	A
HMHAA280	TLP280	A
H11A1	TLP631	A
H11AA1	TLP630	A
H11AG1	TLP331	A
H11B1	TLP571	A
H11C1	TLP541G	A
H11D1	TLP371	C
H11G1	TLP371	A
MOC3021-M	TLP3021(S)	A
MOC3022-M	TLP3022(S)	A
MOC3023-M	TLP3023(S)	A
MOC3041-M	TLP3041(S)	A
MOC3042-M	TLP3042(S)	A
MOC3043-M	TLP3043(S)	A
MOC3051-M	TLP3051(S)	A
MOC3052-M	TLP3052(S)	A
MOC3061-M	TLP3061(S)	A
MOC3062-M	TLP3062(S)	A
MOC3063-M	TLP3063(S)	A

COSMO

Part Number	TOSHIBA Part Number	Lv
K1010	TLP421	A
K1020	TLP621-2(T)	A
K2010	TLP631	B
K3010	TLP620(T)	B
KP3020	TLP620-2(T)	B
KP4010	TLP627(T)	A
KP4020	TLP627-2(T)	A
K5010	TLP371	A
K6010	TLP630	A
KPS2801	TLP281	A
KPC354NT	TLP180(T)	B
KPC355NT	TLP127	A
KPC357NT	TLP181(T)	A
KPC452	TLP127	A

LITEON

Part Number	TOSHIBA Part Number	Lv
LTV-123	TLP421	A
LTV-816	TLP421	A
LTV-817	TLP421	A
LTV-851	TLP628	A
LTV-356T	TLP181(T)	A
LTV-357T	TLP181(T)	A
LTV-814	TLP620(T)	B
LTV-814H	TLP320	A
LTV-354T	TLP180(T)	B
LTV-815	TLP627(T)	A
LTV-852	TLP627(T)	A
LTV-352T	TLP127	A
LTV-355T	TLP127	B
MOC3020	TLP3020(S)	A
MOC3021	TLP3021(S)	A
MOC3022	TLP3022(S)	A
MOC3023	TLP3023(S)	A
MOC3051	TLP3051(S)	A
MOC3052	TLP3052(S)	A
MOC3061	TLP3061(S)	A
MOC3062	TLP3062(S)	A
MOC3063	TLP3063(S)	A

Agilent

Part Number	TOSHIBA Part Number	Lv
HCPL-M600	TLP115A	A
HCPL-M601	TLP115A	A
HCPL-M611	TLP115A	A
HCPL-M452	TLP114A	A
HCPL-M453	TLP114A	A
HCPL-M456	TLP114A	A
HCPL-2601	TLP2601	A
HCPL-2611	TLP2601	A
HCPL-2201	TLP555	B
HCPL-2530	TLP2530	A
HCPL-2531	TLP2531	A
HCPL-2630	TLP2631	A
HCPL-2631	TLP2631	A
HCPL-3120	TLP350	A
HCPL-3140	TLP351	A
HCPL-3150	TLP351	A
HCPL-3180	TLP350	B
HCPL-314J	TLP701 x2	C
HCPL-4504	TLP559	A
HCPL-0708	TLP116	B
HCPL-181	TLP181(T)	A
HCPL-354	TLP180(T)	B
HCPL-814	TLP620(T)	B
HCPL-817	TLP421	A

Vishay

Part Number	TOSHIBA Part Number	Lv
K817P	TLP421	A
SFH610A	TLP421	A
SFH614A	TLP628	A
SFH615A	TLP421	A
SFH617A	TLP421	A
SFH618A	TLP624	B
TCET1100	TLP421	A
SFH690xT	TLP181(T)	A
TCMT1100	TLP281	A
TCMT4100	TLP281-4	A
SFH628A	TLP620(T)	B
K815P	TLP627(T)	A
SFH612A	TLP627(T)	A
SFH619A	TLP627(T)	A
SFH655A	TLP627(T)	A
SFH692AT	TLP127	A
TCED1100	TLP627(T)	A
IL66	TLP371	A
IL66B	TLP372	A
IL255	TLP330	A

Code
A: Direct replacement
B: Smaller package size
C: Electrical improvement (pin layout changed)

9 Competitor Cross Reference

9.2 Photorelays

NEC

Part Number	TOSHIBA Part Number	Lv
PS2501-1	TLP421	A
PS2561-1	TLP421	A
PS2571-1	TLP421	A
PS2581-1	TLP421F	A
PS2505-1	TLP620(T)	B
PS2565-1	TLP620(T)	B
PS2502-1	TLP627(T)	A
PS2562-1	TLP627(T)	A
PS2532-1	TLP627(T)	A
PS2533-1	TLP627(T)	A
PS2521-1	TLP629	B
PS2525-1	TLP320	B
PS2701-1	TLP181(T)	A
PS2761-1	TLP181(T)	A
PS2705-1	TLP180(T)	A
PS2765-1	TLP180(T)	A
PS2702-1	TLP127	A
PS2801-1	TLP281	A
PS2801-4	TLP281-4	A
PS2861-1	TLP281	A
PS2805-1	TLP280	A
PS2805-4	TLP280-4	A
PS2865-1	TLP280	A
PS2811-1	TLP283	B
PS2811-4	TLP283-4	B
PS8601	TLP759	B
PS8602	TLP759	A
PS9613	TLP759(IGM)	A
PS8701	TLP114A	B
PS8101	TLP114A	B
PS9713	TLP114A(IGM)	B
PS9113	TLP114A(IGM)	B
PS9601	TLP554	A
PS9614	TLP554	B
PS9714	TLP115A	B
PS9114	TLP115A	B
PS9715	TLP115A	B
PS9115	TLP115A	B
PS9701	TLP115A	A
PS7141-1A	TLP597GA	A
PS7141-2A	TLP227GA-2	A
PS7141-1B	TLP4597G	B
PS7141-2B	TLP4227G-2	B
PS7141-1C	TLP4006G	B
PS7341C-1A	TLP594G	B
PS7341C-2A	TLP224G-2	B
PS7241-1A	TLP176GA	A
PS7241-2A	TLP206GA	A
PS7241-1B	TLP4176G	B
PS7241-2B	TLP4206G	B
PS7241-1C	TLP4026G	B

SHARP

Part Number	TOSHIBA Part Number	Lv
PC123	TLP421	A
PC817	TLP421	A
PC813	TLP620	A
PC815	TLP627	A
PC357NT	TLP181(T)	A
PC354NT	TLP180(T)	A
PC355NT	TLP127	A
PC3H7	TLP281	A
PC3H3	TLP280	A
PC3H21	TLP525G	A
PC410	TLP115A	A
PC942	TLP351	A
PC923	TLP351	A
S2S3	TLP260J	B
S2S4	TLP161J	B
PR36MF11NSZ	TLP3506	B
PR36MF12NSZ	TLP3506	B
S21MD3V	TLP3051(S)	A
S201D01	TLP3526	B
S201D02	TLP3527	B

AROMAT(NaIS)

Part Number	TOSHIBA Part Number	Lv
AQV210	TLP592G	A
AQV210E	TLP597G	A
AQV210EH	TLP797GA	A
AQV210S	TLP192G	A
AQV212	TLP592A	A
AQV212S	TLP197A	A
AQV214	TLP597GA	A
AQV214E	TLP597G	A
AQV214EH	TLP797GA	A
AQV214H	TLP797GA	A
AQV214S	TLP797GA	A
AQV215	TLP597A	B
AQV216	TLP797J	A
AQV217S	TLP197D	A
AQV410EH	TLP4592G	A
AQV414	TLP4592G	A
AQV414E	TLP4597G	A
AQV414S	TLP4197G	A
AQW210	TLP222G-2	A
AQW210S	TLP202G	A
AQW212	TLP222A-2	A
AQW214	TLP227GA-2	A
AQW215	TLP222A-2	B
AQW217	TLP222G-2	A
AQW414	TLP4222G-2	A
AQW610S	TLP4026G	A
AQW614	TLP4007G	A
AQY210EH	TLP227G	A
AQY210LS	TLP174G	A
AQY210S	TLP174G	A
AQY214EH	TLP227G	A
AQY214S	TLP176GA	A
AQY410EH	TLP4227G	A
AQY414EH	TLP4227G	B
AQY414S	TLP4176G	A
AQY221N1S	TLP3113/TLP3116	B
AQY221N2S	TLP3113/TLP3116	B
AQY221R2V	TLP3215	A
AQY221N2V	TLP3215	A
AQY221N2V	TLP3216	A

AUSTRIA
EBV Elektronik
Tel: +43-1-89-152 0
Fax: +43-1-89 152 30
http://www.ebv.com

Spoerle Electronic
Distribution International
Tel: +43-1-360460
Fax: +43-1-3692273
http://www.spoerle.com

BELGIUM
EBV Elektronik
Tel: +32-2-7160010
Fax: +32-2-7208152
http://www.ebv.com

Glyn Benelux
Please contact the Netherlands office
opto@glyn.de
http://www.glyn.de

Spoerle Electronic
Distribution International
Tel: +32-2-7254660
Fax: +32-2-7254511
http://www.spoerle.com

CZECH REPUBLIC
EBV Elektronik
Tel: +420-(0)2-66 31 30 31
Fax: +420-(0)2-6889078
http://www.ebv.com

Spoerle Electronic spol.sro.
Tel: +420-(0) 2-71742000
Fax: +420-(0) 2-71742001
http://www.spoerle.com

DENMARK
Arrow Nordic
Tel: +45 44 50 82 00
Fax: +45 44 50 82 10
http://www.arrowdk.com

EBV Elektronik
Tel: +45 86 25 04 66
Fax: +45 86 25 06 60
http://www.ebv.com

ESTONIA
Arrow-Fiel Eesti A/S
Tel: +372 650 3288
http://www.arrow.com

FINLAND
Arrow Nordic
Tel: +358 9 47 66 6388
Fax: +358 9 47 66 6430
www.arrowfi.com

EBV Elektronik
Tel: +358 9 27052790
Fax: +358 9 27095498
http://www.ebv.com

FRANCE
Arrow Electronique S.A.
Tel: +33 1 49 78 49 00
Fax: +33 1 49 78 06 99
http://www.arrow.com

Tekelec Europe S.A
Tel: +33 1 56 30 24 25
Fax: +33 1 56 30 25 25

EBV Elektronik GmbH Co.KG
Tel: +33 1 40 96 30 00
Fax: +33 1 40 96 30 30
http://www.ebv.com

GERMANY
EBV Elektronik Vertriebs GmbH
Tel: +49 (0)8121-774-0
Tel: +49 (0)8121-774-422
http://www.ebv.com

Glyn Jones GmbH & Co. KG
Tel: +49 (0)6126-590222
Fax: +49 (0)6126-590111
http://www.glyn.de

Spoerle Electronic
Tel: +49 (0)6103-3040
Fax: +49 (0)6103-304201
http://www.spoerle.com

GREECE
Arrow Electronics Hellas
Tel: +30 (210) 9020165
Fax: +30 (210) 9022118
http://www.arrow.com

EBV Elektronik
Tel: +30 (210) 3414300
Fax: +30 (210) 3414304
http://www.ebv.com

HUNGARY
EBV Elektronik
Tel: +36-(0)1 436 7211
Fax: +36-(0)1 436 7215
http://www.ebv.com

Spoerle Electronic
Tel: +36-(0)1-350 6275/76
Fax: +36-(0)1-350 6277
http://www.spoerle.com

ISRAEL
EBV Elektronik
Tel: +972-9709606990
Fax: +972-98-852229
http://www.ebv.com

ITALY
EBV Elektronik S.r.l
Tel: +39 02 66 09 62 90
Fax: +39 02 66 01 70 20
http://www.ebv.com

Lasi Elettronica
Tel: +39 02 66 14 31
Fax: +39 02 66 10 13 85
www.arrowlasi.com

IRELAND
Abacus Polar
Tel: +353 61480 166
Fax: +353 61480 777

Arrow Electronics Ireland
Tel: +353 1 830 7207 /
7522
Fax: +353 1 830 7201
http://www.arrowireland.com

EBV Ireland
Tel: +353 1 465 4034
Fax: +353 1 456 4035
http://www.ebv.com

NETHERLANDS
EBV Elektronik
Tel: +31-346 583010
Fax: +31-346 583025
http://www.ebv.com

Glyn Benelux
Tel: +31 4020497 00
Fax: +31 4020497 84
opto@glyn.de
http://www.glyn.de

Spoerle Electronic Distribution
International
Tel: +31-306 391234
Fax: +31-306 391205
http://www.spoerle.com

NORWAY
Arrow Nordic
Tel: +47 21 30 65 00
Fax: +47 21 30 65 80
www.arroweurope.com/
northern

EBV Elektronik
Tel: +47 22 67 17 80
Fax: +47 22 67 17 89
http://www.ebv.com

POLAND
EBV Elektronik
Tel: +48-(0) 71-
3422944/64/87
Fax: +48-(0) 71-3422910
http://www.ebv.com

Spoerle Electronic Polska Sp. z o.o.
Tel: +48-(0)22-8569090
Fax: +48-(0)22-6465228
http://www.spoerle.com

RUSSIA
EBV Elektronik
Tel: +7 095 976 1176
Fax: +7 095 976 4808
http://www.ebv.com

SLOVENIA
EBV Elektronik
Tel: +386 (0)61 300 0371
Fax: +386 (0)61 133 0457
http://www.ebv.com

SOUTH AFRICA
Avnet Kopp (Pty) Ltd
Tel: +27 11 444 2333
Fax: +27 11 444 7778
http://www.avnet.co.za

SPAIN
Arrow Iberia
Tel: +34 91 304 3040
Fax: +34 91 327 2472
www.arrow-iberia.com

EBV Elektronik
Tel: +34 91 804 32 56
Fax: +34 91 804 41 03
http://www.ebv.com

SWEDEN
Arrow Nordic
Tel: +46 (0)8 56 26 57 00
Fax: +46 (0)8 56 26 55 05
www.arroweurope.com/
northern

EBV Elektronik
Tel: +46 (0)40 592 100
Fax: +46 (0)40 592 101
http://www.ebv.com

SWITZERLAND
EBV Elektronik
Tel: +41-(0)1-745 61 61
Fax: +41-(0)1-745 61 00
http://www.ebv.com

Spoerle Electronic Distribution
International
Tel: +41-1-817 62 62
Fax: +41-1-817 62 00
http://www.spoerle.com

TURKEY
Arrow Elektronik Ticaret A.S.
Tel: +90 216 575 1820
Fax: +90 216 575 1830
www.arroweurope.com

EBV Elektronik
Tel: +90-(0)216 463 1352
Fax: +90-(0)216 463 1355
http://www.ebv.com

UNITED KINGDOM
Abacus Polar Holding Ltd
Tel: +44 1525 858100
Fax: +44 1525 858101
http://www.abacus.co.uk

Anglia Electronics
Tel: +44 1945 474747
Fax: +44 1945 474849

Arrow Electronics (UK) Ltd
Tel: +44 1279 441144
Fax: +44 1279 441687
http://www.arrowuk.com

BFI Optilas
Tel: +44 (0) 1908 326326
Fax: +44 (0) 1908 221110

EBV Elektronik
Tel: +44 1628 783688
Fax: +44 1628 783811
http://www.ebv.com

Trident Displays
Tel: +44 (0) 1737 780790
Fax: +44 (0) 1737 771908

RESTRICTIONS ON PRODUCT USE

- TOSHIBA is continually working to improve the quality and reliability of its products. Nevertheless, semiconductor devices in general can malfunction or fail due to their inherent electrical sensitivity and vulnerability to physical stress. It is the responsibility of the buyer, when utilizing TOSHIBA products, to comply with the standards of safety in making a safe design for the entire system, and to avoid situations in which a malfunction or failure of such TOSHIBA products could cause loss of human life, bodily injury or damage to property. 02123.A
- In developing your designs, please ensure that TOSHIBA products are used within specified operating ranges as set forth in the most recent TOSHIBA products specifications. Also, please keep in mind the precautions and conditions set forth in the „Handling Guide for Semiconductor Devices,“ or „TOSHIBA Semiconductor Reliability Handbook“ etc., 02123.A
- The TOSHIBA products listed in this document are intended for usage in general electronics applications (computer, personal equipment, office equipment, measuring equipment, industrial robotics, domestic appliances, etc.). These TOSHIBA products are neither intended nor warranted for usage in equipment that requires extraordinarily high quality and/or reliability or a malfunction or failure of which may cause loss of human life or bodily injury („Unintended Usage“). Unintended Usage include atomic energy control instruments, airplane or spaceship instruments, transportation instruments, traffic signal instruments, combustion control instruments, medical instruments, all types of safety devices, etc.. Unintended Usage of TOSHIBA products listed in this document shall be made at the customers own risk. 02123.B
- The information contained herein is presented only as a guide for the applications of our products. No responsibility is assumed by TOSHIBA CORPORATION for any infringements of intellectual property or other rights of the third parties which may result from its use. No license is granted by implication or otherwise under any intellectual property or other rights of TOSHIBA CORPORATION or others.
- The information contained herein is subject to change without notice.

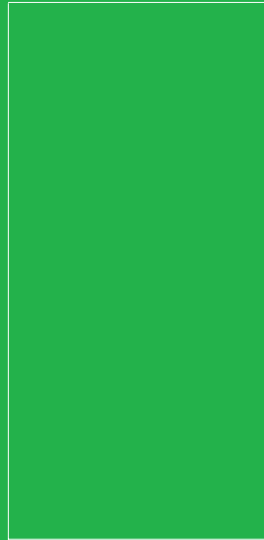
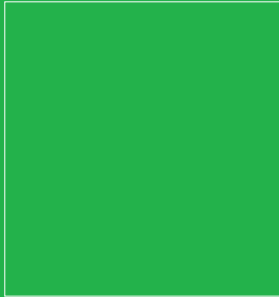
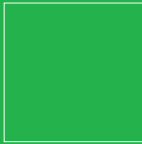

Toshiba Electronics Europe

Hansaallee 181

D-40549 Düsseldorf

Germany

tel: +49 (211) 5296 0

fax: +49 (211) 5296 400

www.toshiba-europe.com

<http://www.toshiba.co.jp/index.htm>

For further product information, brochures and datasheets please have a look at our internet sites:

Datasheets: http://www.semicon.toshiba.co.jp/eng/search/ft_datasheet.html

Brochures: <http://www.semicon.toshiba.co.jp/eng/index.html>

TEE Homepage: <http://www.toshiba-components.com>

Toshiba Homepage: <http://www.toshiba.co.jp/index.htm>

TOSHIBA

PHOTOCOUPLER: 0512(D)